



VKBA 6626

Technical Bulletin – October 2015

VKBA 6626



Front Wheel: SMART FORTWO Coupe (451), FORTWO Cabrio (451)



The use of the correct tools for mounting and dismantling the HBU 2.1 is crucial to avoid premature bearing failures.

The HBU 2.1, which has become a common wheel bearing design on the market, requires the use of special tools for dismantling and especially for mounting the bearing on the vehicle.

SKF's aim is to provide the customer with a complete solution and can now also offer the needed tools for the application of that special bearing design. With this new tool set SKF is able to cover the mounting and dismantling for more than 20 million cars on European roads.

Some important facts about HBU 2.1 and the use of SKF tools VKN 600, VKN 601 and VKN 602-1 for installation of the bearing:

The characteristics of an HBU 2.1

- It is a pre-assembled unit with defined and preset bearing clearance, combining the bearing with the flange.
- The rotating inner ring flange, with threaded holes or studs, has a spigot designed to center and mount brake disc and wheel.
- Possible integration of a magnetic impulse ring in the seal of the bearing, providing signals for safety systems like ASB, ASR and ESP.
- The bearing comes with or without a snap ring.

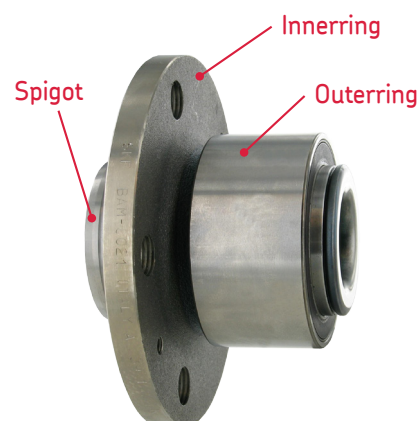

Fitting Instructions for a HBU 2.1 with SKF tools set:

1. Use VKN 601 to remove the old bearing from the steering knuckle (VKN 602-1, which is an hydraulic cylinder, can be used as a completion for VKN 601).
2. Carefully clean the surface in the steering knuckle and make sure, that there are no heavy or deep scratches or any other damages in the housing bore.
3. Use VKN 600, which is developed with the correct pre-defined force, to install the new HBU 2.1 pressing **on the outer ring side** of the bearing.

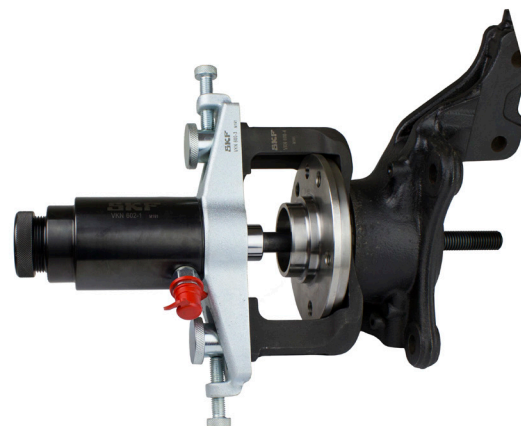

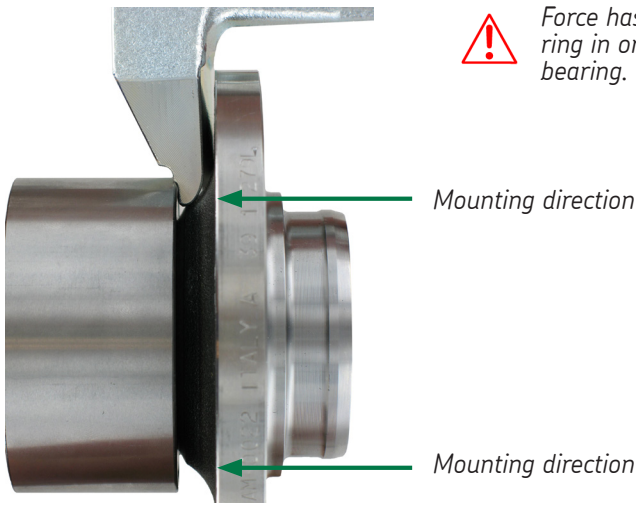

Force has to be put on the outer ring in order to **not** damage the bearing.



Pictures on premature bearing failures.

This mounting step is the most critical part, as the wrong tools lead to premature bearing failures.

When using a standard hydraulic press, force is often applied to the flange, when pressing into the knuckle. The force cascades through the inner ring to the rolling elements and lastly to the outer ring. This applied force causes damages on the bearing, which leads to water ingress and early failure are one of the most common consequences.

The SKF HBU 2.1 tool sets (VKN 600, VKN 601, VKN 602-1):

- Cover the whole HBU 2.1 range.
- Have a flexible mounting feet to insert bearing housing of varying sizes, covering all diameters between 62 and 85 mm.
- Allow easy and fast mounting (VKN 600) and dismounting (VKN 601) without removing the knuckle from the car and even the ABS sensor can stay in place.
- Include a link to digital instructions with step-by-step fitting guidelines.

For more info about SKF HBU 2.1 tools please look at our homepage www.vsm.skf.com

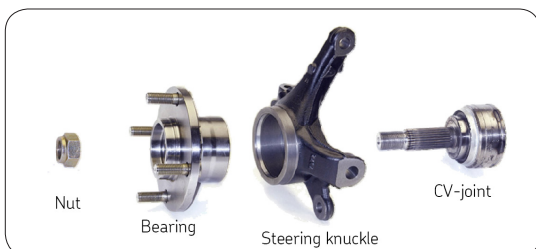

Bearing HBU 2.1 and surrounding components.



VKN 600 HBU 2.1 mounting tool.



VKN 601 HBU 2.1 dismounting tool.



VKN 602-1 optional hydraulic cylinder.

Install confidence
www.vsm.skf.com

© SKF is a registered trademark of the SKF Group.

© SKF Group 2015

The contents of this publication are the copyright of the publisher and may not be reproduced (even extracts) unless written permission is granted. Every care has been taken to ensure the accuracy of the information contained in this publication but no liability can be accepted for any loss or damage whether direct, indirect or consequential arising out of the use of the information contained herein.

