



VKPC 95898

Teknisk bulletin – mars 2011



HYUNDAI Elantra, i20, i30, i30 CW Estate
KIA Carens II, Cerato, CEE'D Hatchback, CEE'D Estate, SOUL



OE/SKF DESIGNUTVIKLING
VKPC 95872 erstattes av VKPC 95898



OE #: HYUNDAI / KIA 25100 2B000 erstattes av 25100-2B700.

BILPRODUSENT	MODELL	MOTOR	MOTORKODER
HYUNDAI	Elantra, i20, i30, i30 CW Estate	1.4, 1.6	G4ED-G, G4GA,
KIA	Carens II, Cerato, CEE'D Hatchback, CEE'D Estate, SOUL	1.4, 1.6	G4FC, G4FA, G4ED

HYUNDAI OE har endret designen av vannpumpen på tidlige bilmodeller.

HYUNDAI har sluttet å levere den gamle vannpumpen, tilsvarende VKPC 95872 som brukes i motorer fra perioden 2000-2006. HYUNDAI anbefaler å skifte ut den gamle vannpumpen med en med nyutviklet design + sette på en ny skive, som sørger for korrekt reiminnstilling og -montering.

For å følge bilprodusentens spesifikasjoner tilbyr SKF tilsvarende vannpumpe sammen med skiven for å dekke behovet i de gamle motorene, i henhold til instruksen fra Hyundai.



GAMMEL DESIGN

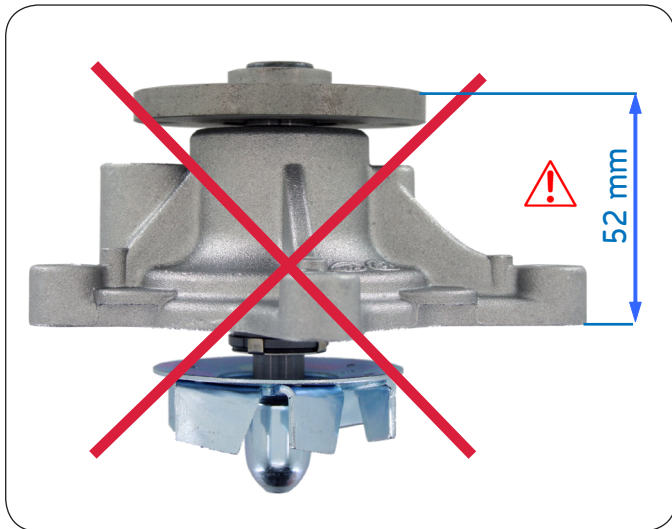

NY DESIGN

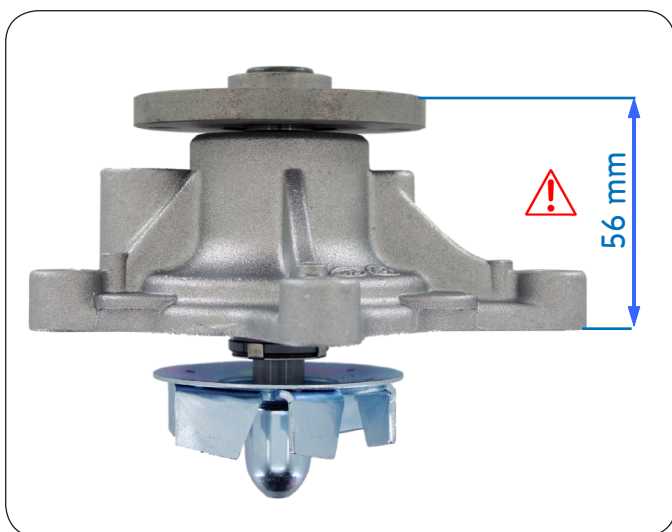

NY SKIVEDESIGN



Ny skive kreves for å sørge for korrekt reiminntstilling.