

## Drosselklappe / Throttle Valve A2C59513207

30.08.2013



1 - Produkt / Product

### TECHNISCHE DATEN / TECHNICAL DATA:

Durchmesser / Diameter = 60 mm

Dichtung / Gasket: VDO A2C59516954 (BMW 11 61 7 528 174; PSA 0348T5)

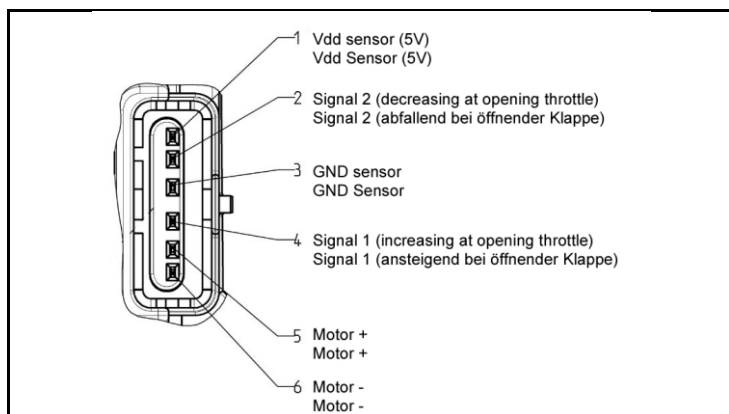

2 - Anschluss / Connector

### ELEKTRISCHE DATEN / ELECTRICAL DATA:

Nennspannung (Motor) /  
Nominal Voltage (Motor) = 12 V

Nennspannung (Positionssensor) /  
Nominal Voltage (Position Sensor) = 5 V

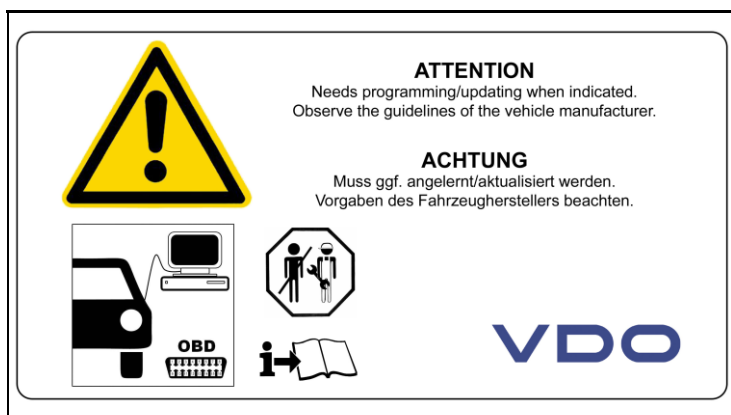

3 - Montage Hinweise / Installation Notes

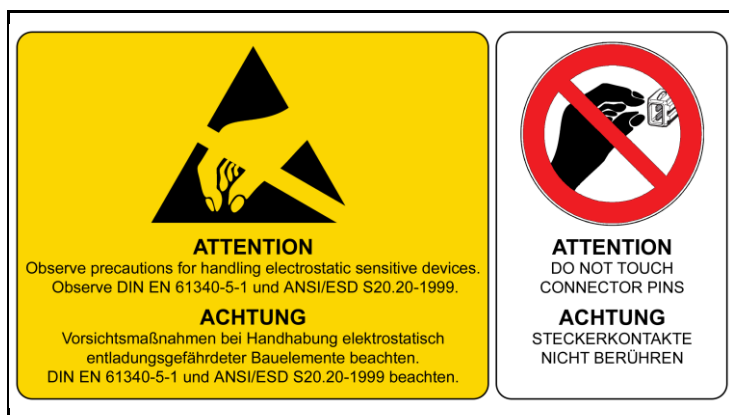

4 - ESD Hinweise / ESD Notes