



LuK GearBOX Repair Solution for Manual Transmission



Disassembly and Assembly
Special Tool

VW, 02J/0A4 Transmissions



The content of this brochure is not legally binding and is solely intended for information purposes. Where legally permissible, all liability on the part of Schaeffler Automotive Aftermarket GmbH & Co. KG in connection with this brochure is excluded.

Schaeffler Automotive Aftermarket GmbH & Co. KG
May 2019

All rights reserved. Any reproduction, distribution, communication, public reproduction or other publication of this brochure in its entirety or in part without prior written consent from Schaeffler Automotive Aftermarket GmbH & Co. KG is not permitted.
Copyright ©

Schaeffler in the automotive aftermarket – more innovation, more quality, more service.



Schaeffler REPERT – the service brand for garage professionals.

With REPERT, we offer a comprehensive service package for the products and repair solutions of the LuK, INA, FAG and Ruville brands. Looking for specific information about damage diagnosis? Are you in need of particular tools to help make your everyday garage routine easier? Whether online portal, service hotline, installation instructions and videos, training seminars, or events – you get all technical services from a single source.

Register now for free, in just a few clicks, at: www.repxpert.com.

Schaeffler in the Automotive Aftermarket – always the first choice for vehicle repair.

Whenever a vehicle needs to go to the garage, our products and repair solutions are first choice to fix them. With our four strong brands LuK, INA, FAG and Ruville, and our service brand REPERT, we are a reliable partner around the world. Whether passenger cars, light and heavy commercial vehicles, or tractors – our optimally tuned components allow fast and professional parts replacement.

Our products are based on a comprehensive systems approach. Innovation, technical expertise, and the highest material and manufacturing quality make us not only one of the leading development partners for vehicle manufacturers, but also a pioneering provider of value-retaining spare parts and complete repair solutions for clutches and clutch release systems, engine and transmission applications, and chassis applications in original-equipment quality – right up to the appropriate special tools.

For over 50 years, we have offered everything needed for transmission repair under the LuK brand. Besides the LuK RepSet family and products for the entire hydraulic release system for professional clutch repair, the portfolio also includes the dual mass flywheel and components for expert repair of transmissions and differentials. It also includes professional solutions for transmission repair of commercial vehicles and tractors.

SCHAEFFLER
REPERT



The spare parts contained in the LuK GearBOX can be assigned to the relevant installation position in the transmission with the help of the parts list and this brochure. The figures in parentheses are used for this purpose, e.g. (1).

Note:

The safety pin (12) is not required for the 02J/0A4 transmission.

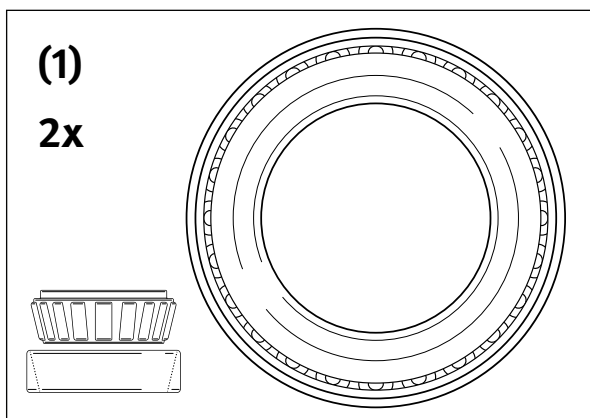

Fig. 1

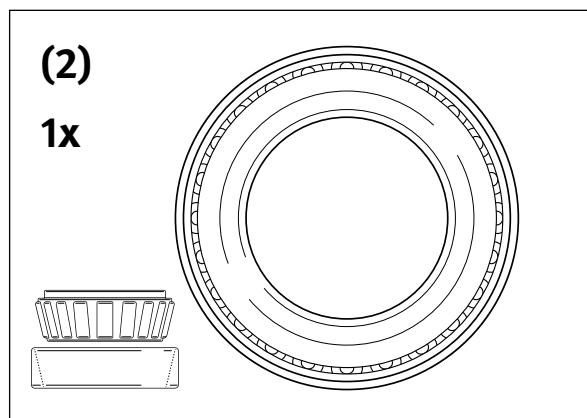

Fig. 2

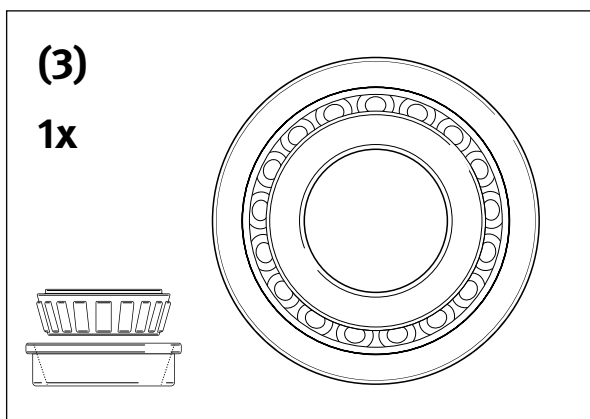

Fig. 3

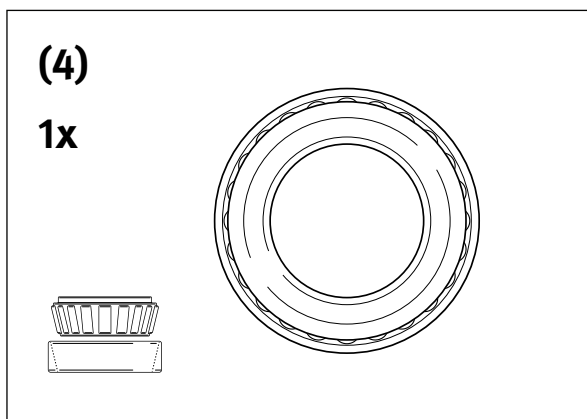

Fig. 4

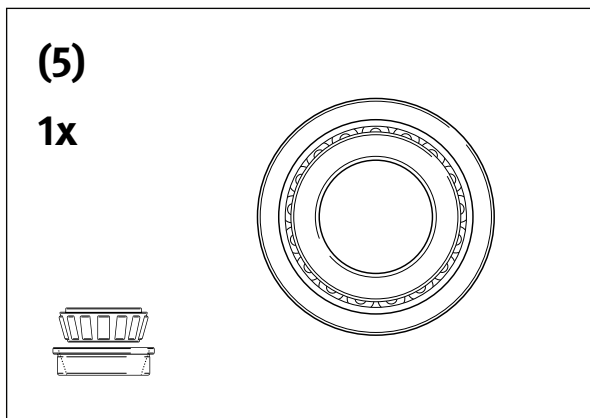

Fig. 5

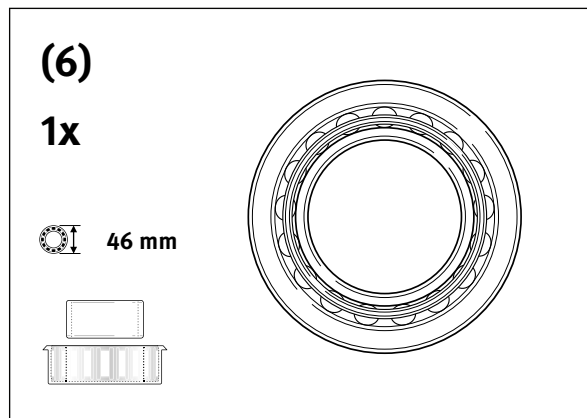

Fig. 6

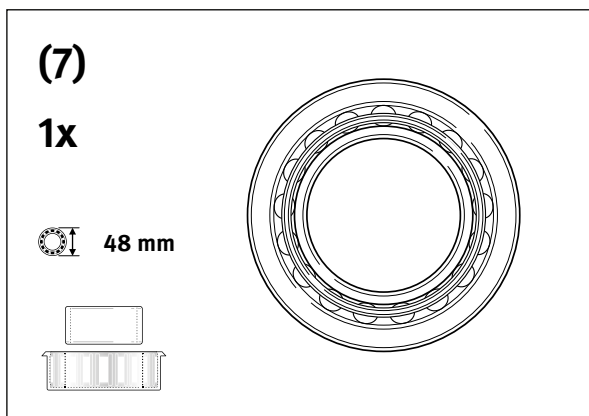

Fig. 7

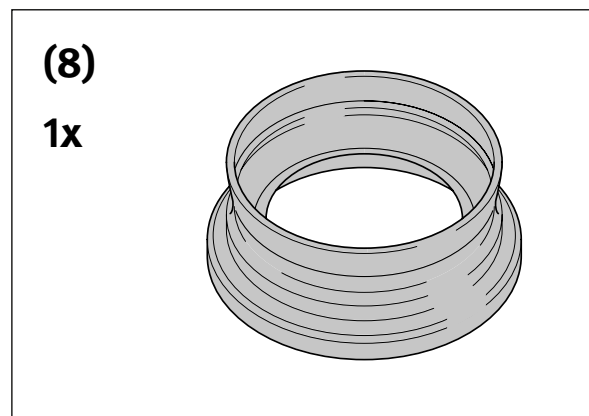

Fig. 8

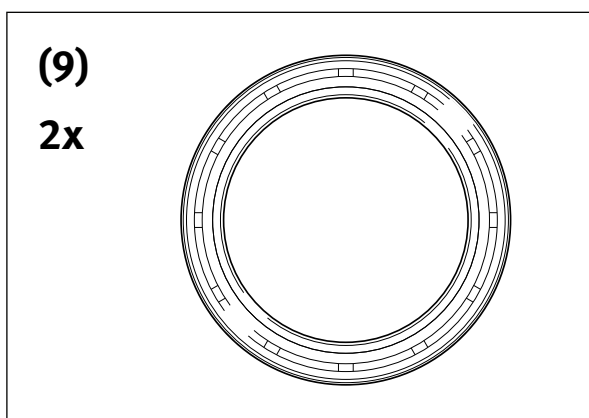

Fig. 9

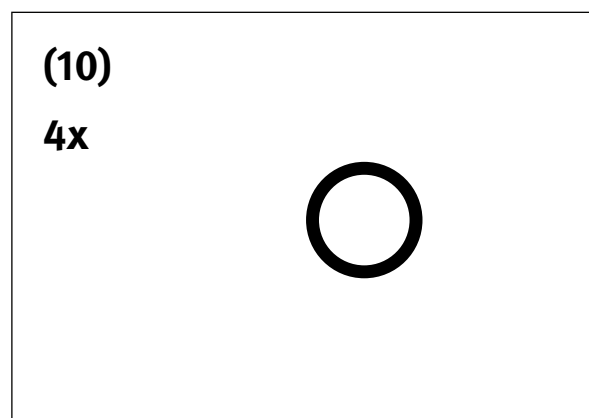

Fig. 10

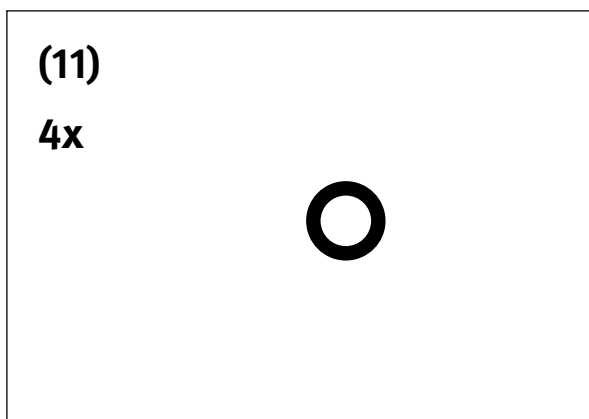

Fig. 11

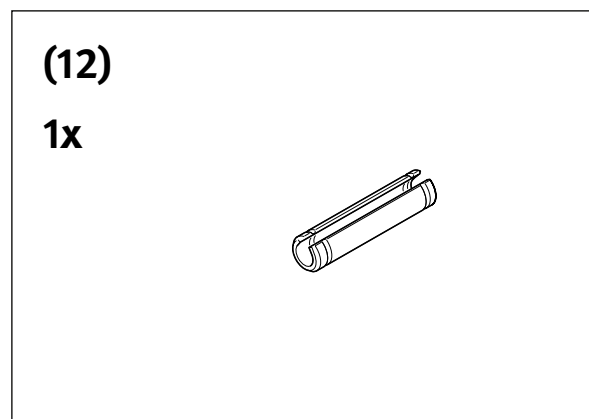

Fig. 12

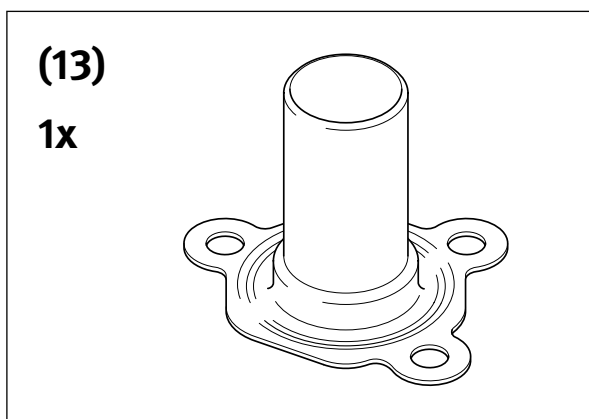

Fig. 13

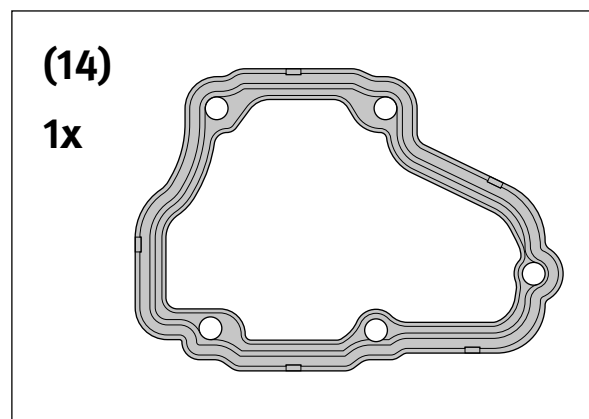

Fig. 14

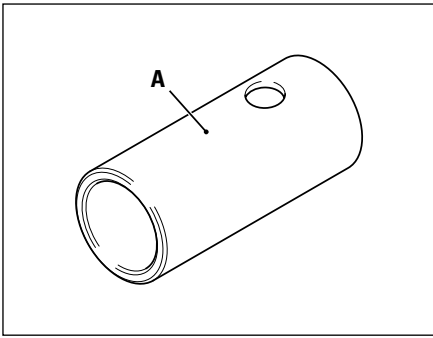

Fig. 15

Press sleeve A:

- For press on the 3rd/4th gear synchro body
- For installing the support bearing for drive and output shafts
- Part number: 400 0472 10

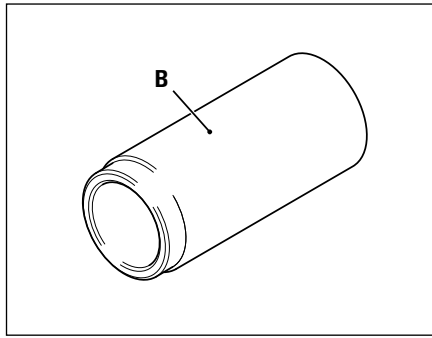

Fig. 16

Press sleeve B:

- For press on the 1st/2nd gear synchro body
- Part number: 400 0473 10

Shim Sets

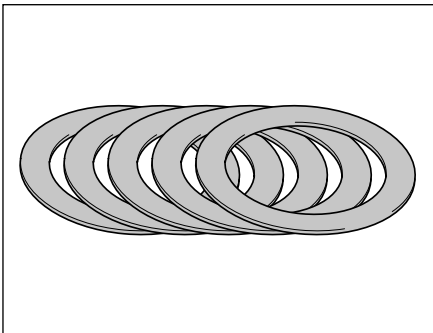

Fig. 17

Shims:

- For adjusting the bearing preload of the tapered roller bearing on the differential
- Outside diameter 67.9 mm
- Part number: 464 0001 10

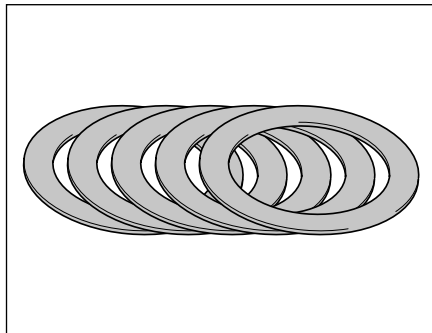

Fig. 18

Shims:

- For adjusting the bearing preload of the tapered roller bearing on the output shaft
- Outside diameter 50.2 mm
- Part number: 464 0002 10

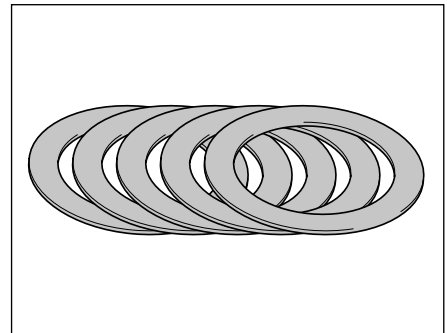

Fig. 19

Shims:

- For adjusting the bearing preload of the tapered roller bearing on the drive shaft
- Outside diameter 69.0 mm
- Part number: 464 0003 10

National and vehicle manufacturers' safety requirements and guidelines must always be observed whenever any work is conducted.

Further information can be found at www.repxpert.com and in our technical brochures.

Support the transmission or transmission housing parts during repair using suitable means (e.g. metal blocks).

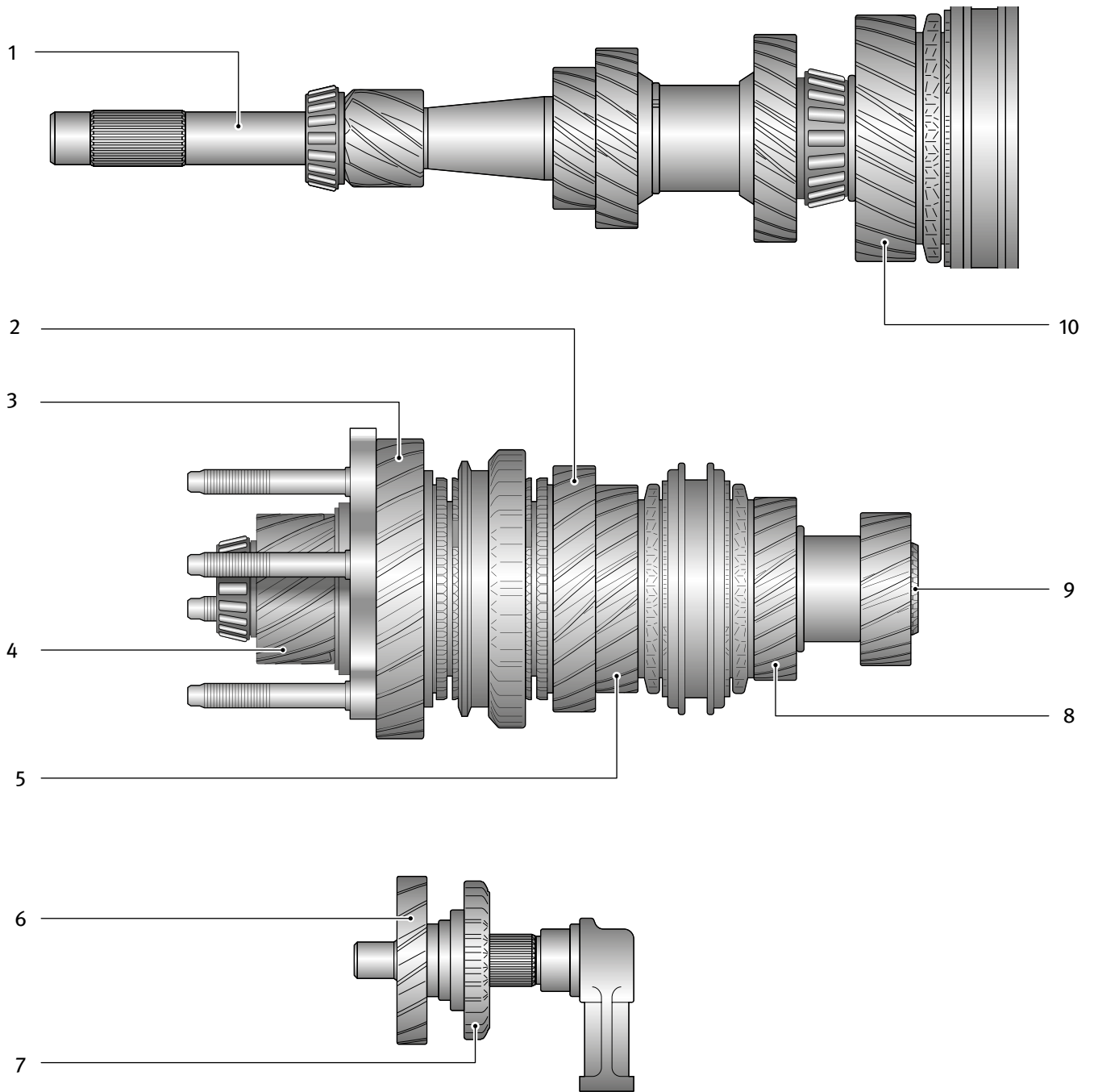

Fig. 20

- | | |
|------------------------------|-----------------------|
| 1. Drive shaft | 6. Reverse gear shaft |
| 2. 2nd gear | 7. Reverse gear idler |
| 3. 1st gear | 8. 4th gear |
| 4. Differential toothed gear | 9. Output shaft |
| 5. 3rd gear | 10. 5th gear |

- Drain transmission fluid and screw drain plug in again
Tightening torque: 30 Nm
- Remove the gearbox in accordance with the vehicle manufacturer's specifications

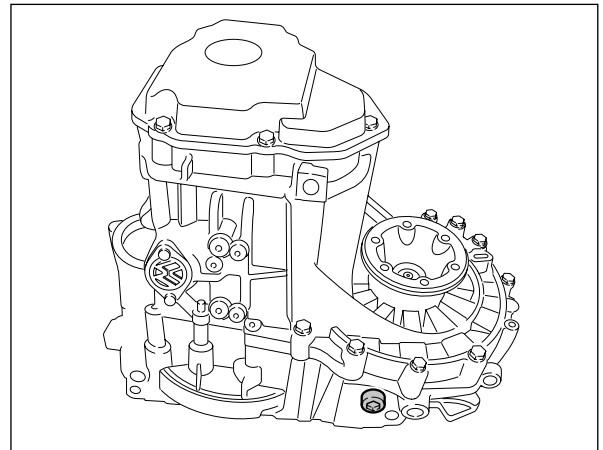

Fig. 21

- Unhook the retaining spring
- Remove the release lever and release bearing

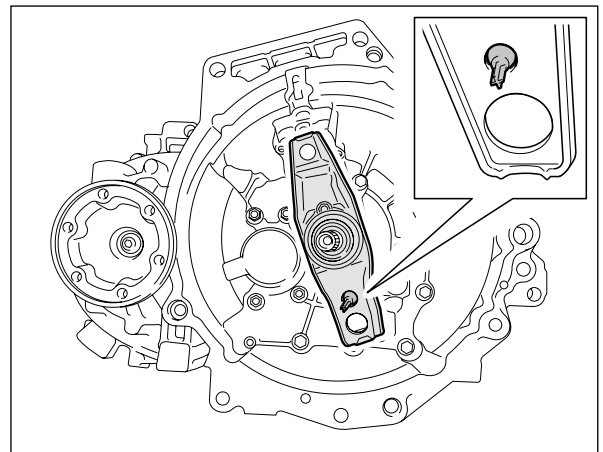

Fig. 22

- Remove the guide sleeve

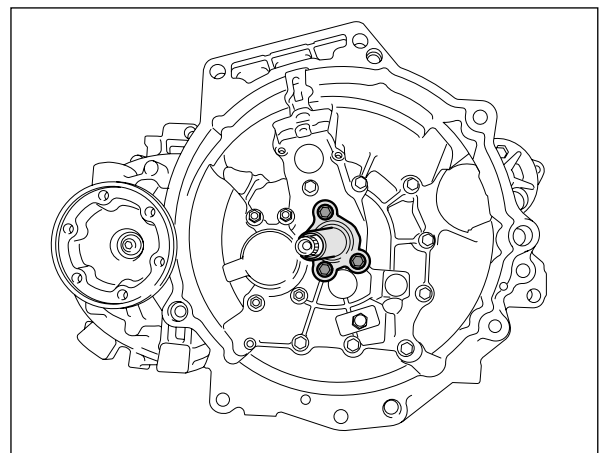

Fig. 23

- Disassemble the flanged shafts along with the pressure spring, thrust washer and conical ring

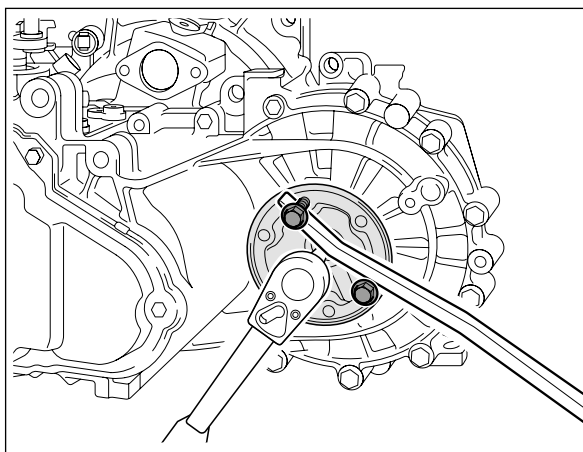

Fig. 24

- Remove the gearbox housing cover of 5th gear
- Clean the sealing surface

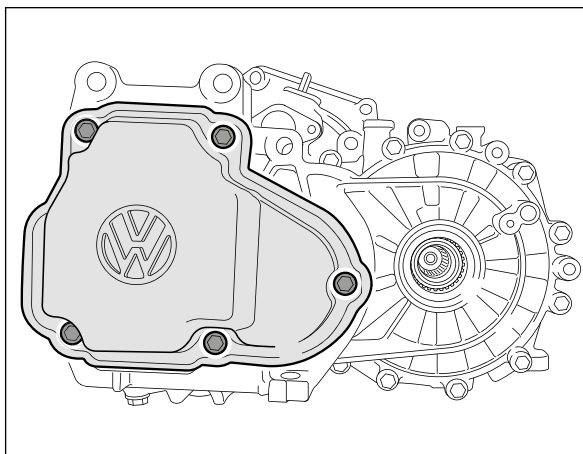

Fig. 25

- Undo screws [1] from bearing journals
- Remove selector fork for 5th gear [2]

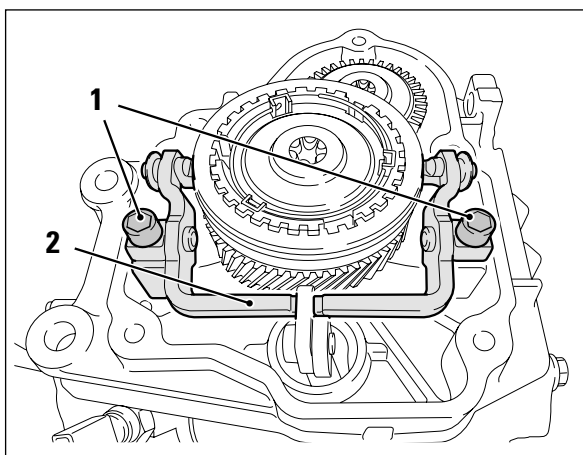

Fig. 26

- Press down shift collar for 5th gear [1], push in gear-shift shaft [2] and rotate anti-clockwise [3]
- Undo screws [4] for synchro unit and 5th gear toothed gear
- Return switching shaft and shift collar to their previous (neutral) position

Note:
 Note the installation position of the two plate springs.

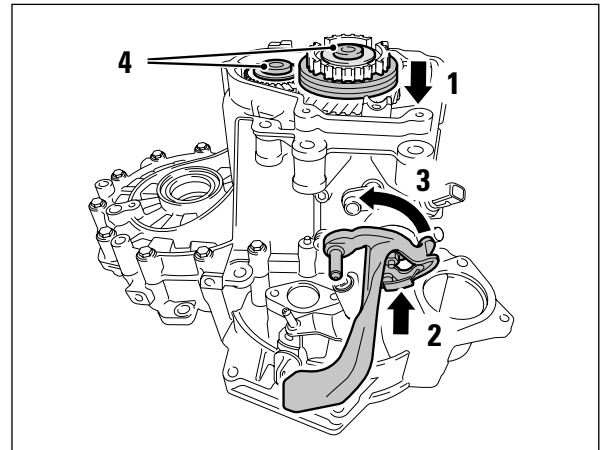

Fig. 27

- Place a puller under idler for 5th gear
- Remove synchron unit and idler from drive shaft

Note:
 Before disassembly, mark the position of the sliding sleeve relative to the synchro. Take care when lifting out synchro unit (shift collar, thrust pieces and spring lock washer) to prevent it from falling apart.

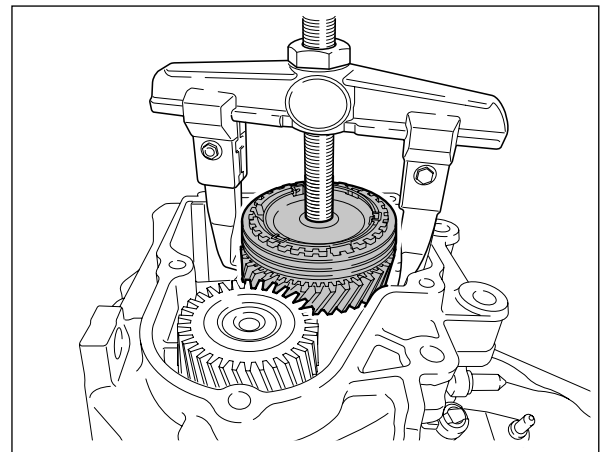

Fig. 28

- Remove 5th gear

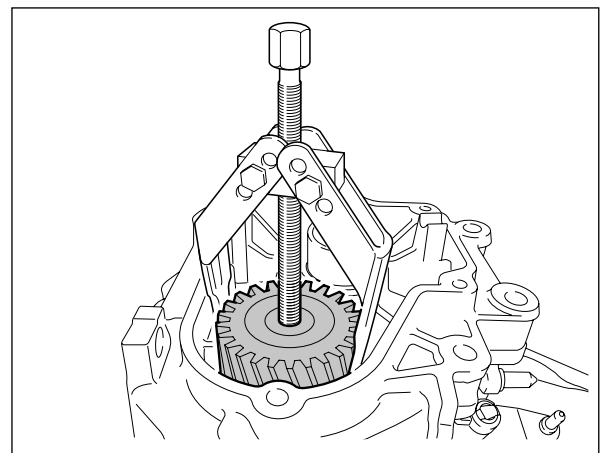

Fig. 29

- Remove retaining clip [1]
- Remove bell crank [2]

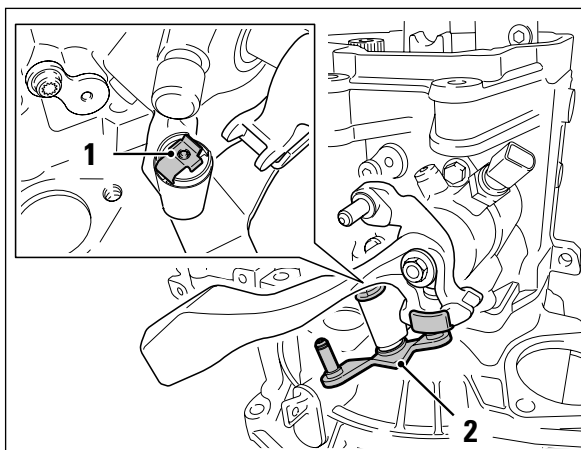

Fig. 30

- Remove gear change assembly weight

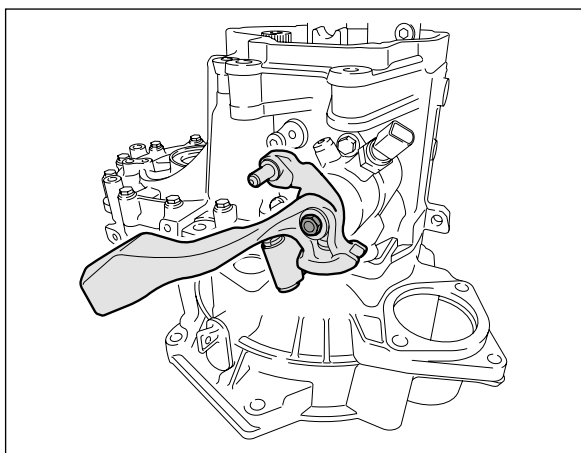

Fig. 31

- Remove gear selector shaft with cover [1] and both bearing journals [2]

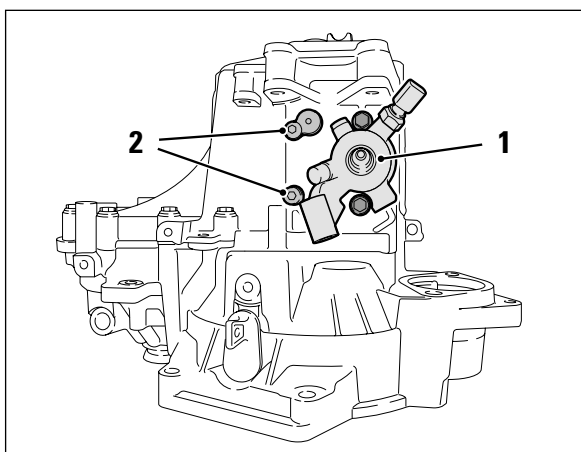

Fig. 32

- Remove both bearing journals [1] and remove cover [2]
- Undo screw on reverse gear [3]

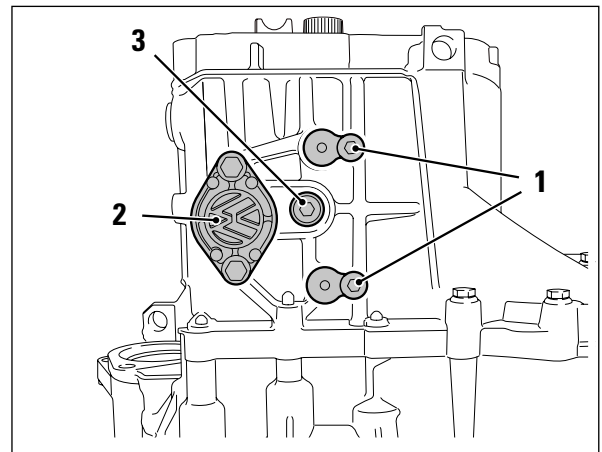

Fig. 33

- Undo screw on reverse gear

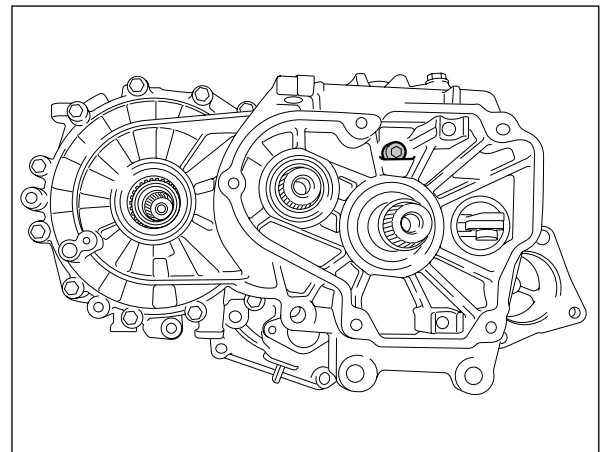

Fig. 34

- Undo screws [1]

Note:
Do **not** loosen the nuts for the output shaft bearing seat [2].

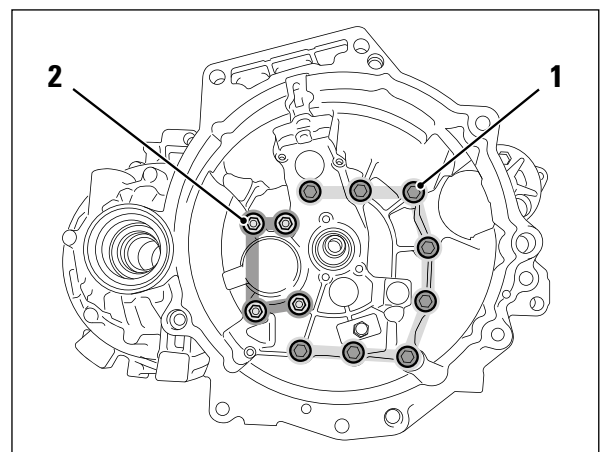

Fig. 35

- Undo screws of transmission housing

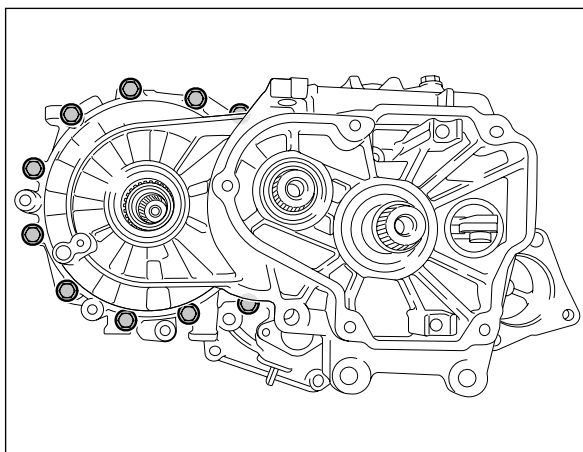

Fig. 36

- Lift the transmission housing upwards

Note:

Do not damage the sealing surfaces.

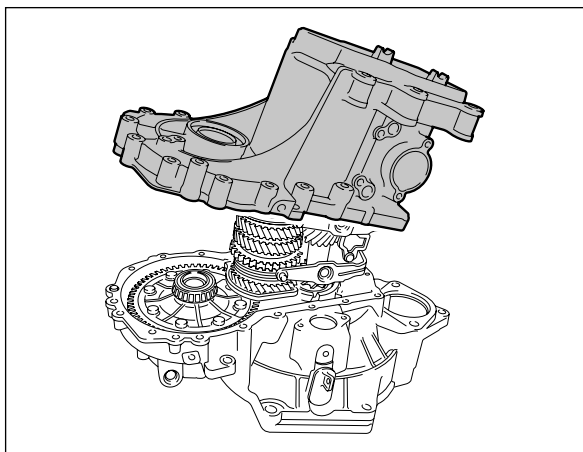

Fig. 37

- Remove gear selector forks and gear selector rails [1]
- Undo screw [2]
- Remove the reverse gear selector mechanism

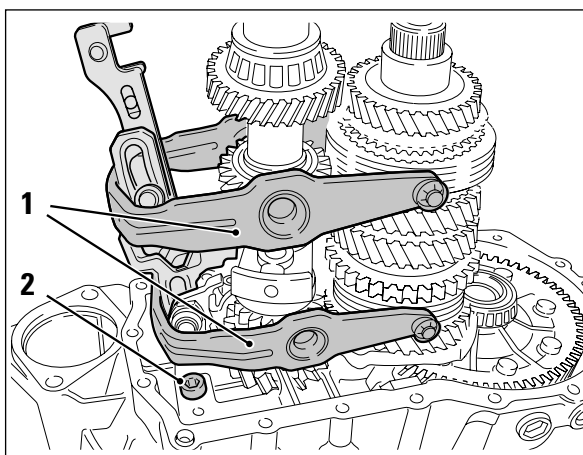

Fig. 38

- Unscrew the nuts for the output shaft bearing seat

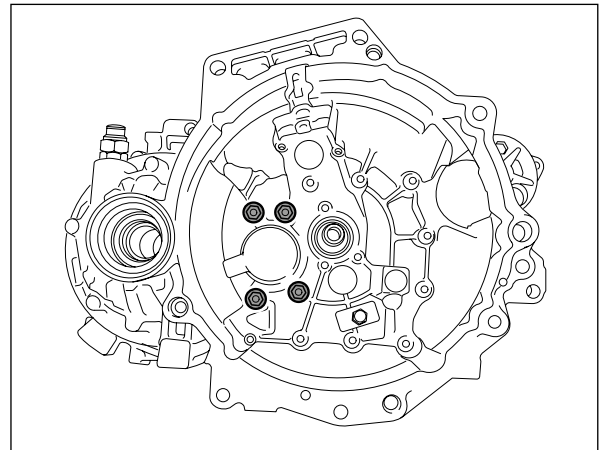

Fig. 39

- Remove reverse idler gear [1], drive shaft [2] and output shaft [3] from the housing one after another
- Lift out the differential [4]
- Remove magnet [5]

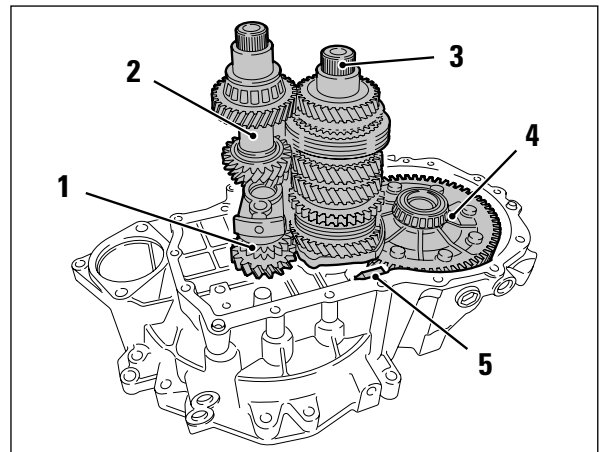

Fig. 40

- Pull out the drive shaft bearing cup on the clutch housing side

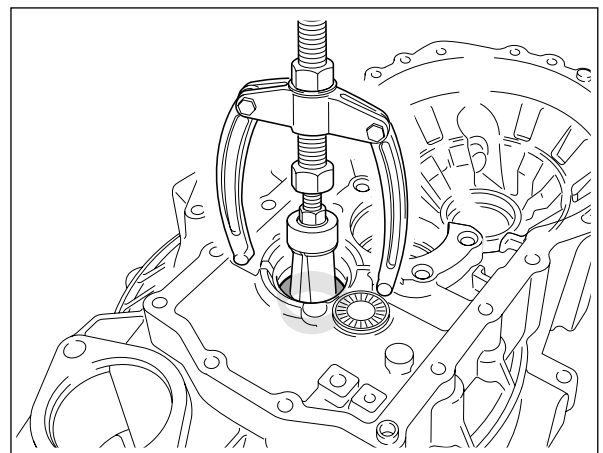

Fig. 41

- Pull out the output shaft bearing cup on the clutch housing side
- Remove the shim

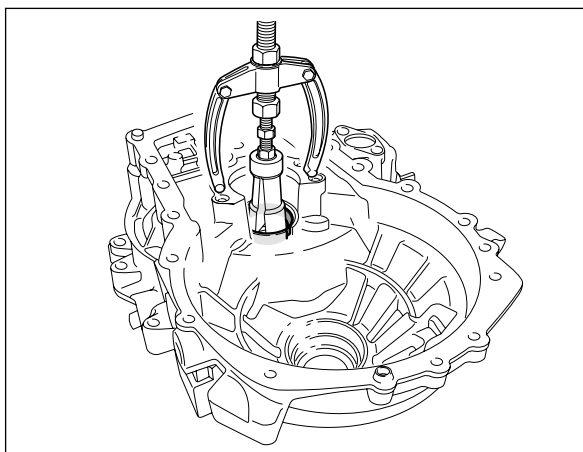

Fig. 42

- Pull out the differential bearing cup on the clutch housing side

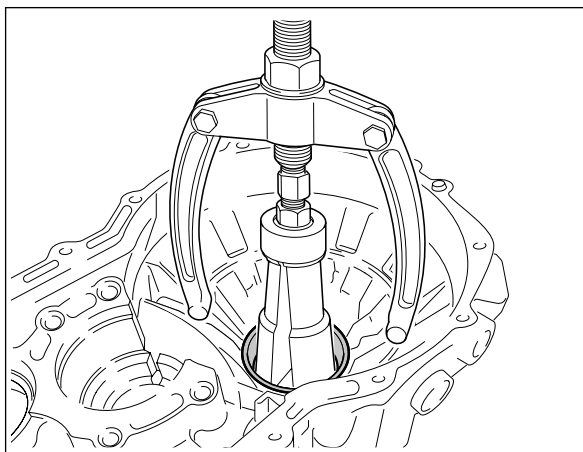

Fig. 43

- Remove the differential seal

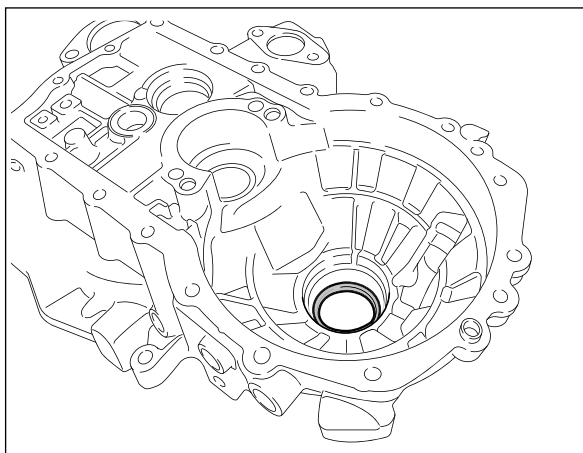

Fig. 44

- Press in the new differential seal (8) or (9)

Note:

Clean the sealing surface.

Follow the non-verbal installation instructions

999 6006 770 (leaflet included with LuK gearbox).

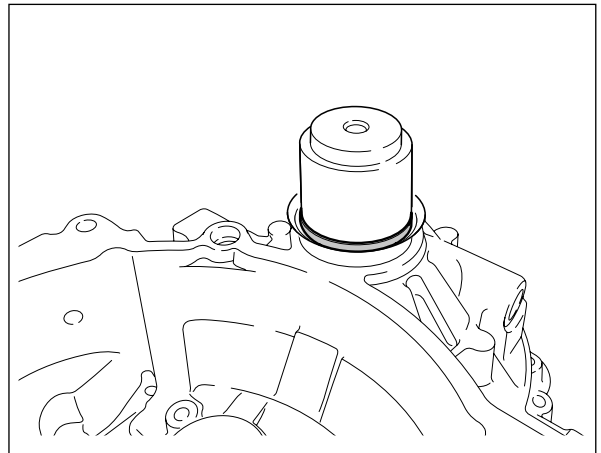

Fig. 45

- Pull out the differential bearing cup from the transmission side
- Remove the shim

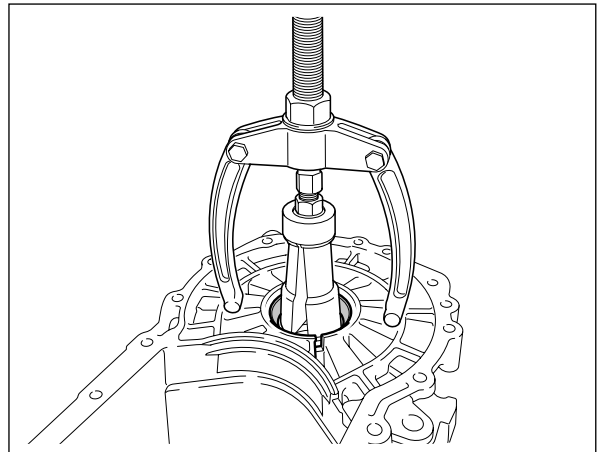

Fig. 46

- Remove the differential seal

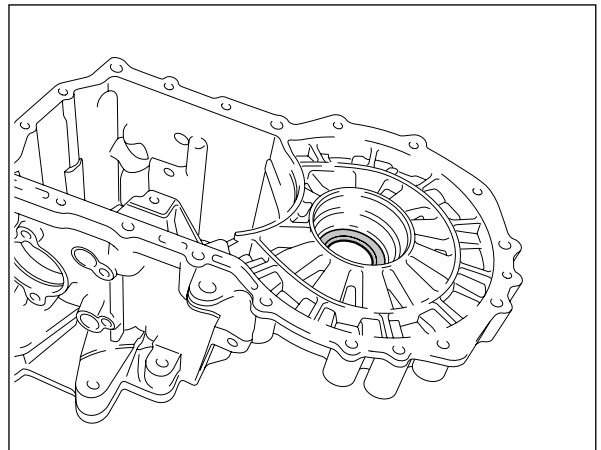

Fig. 47

- Press in the new differential seal (9)

Note:

Clean the sealing surface.

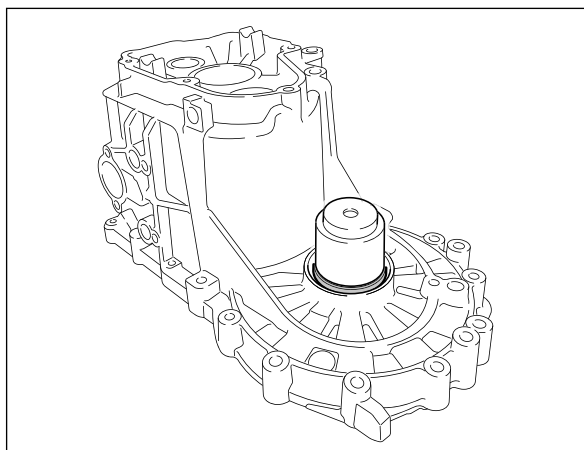

Fig. 48

- Pull out the drive shaft bearing cup on the transmission housing side along with the shim

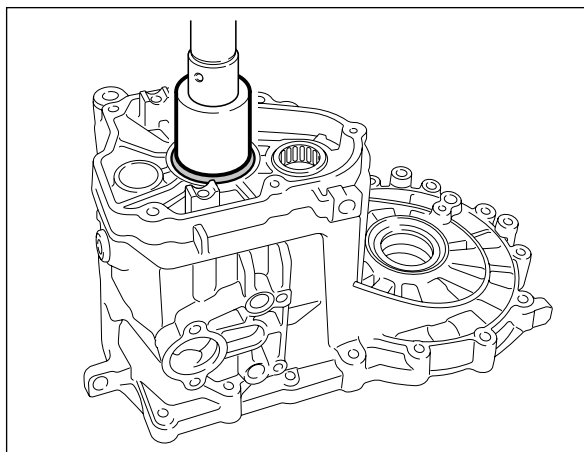

Fig. 49

- Pull out the output shaft roller sleeve on the transmission housing side

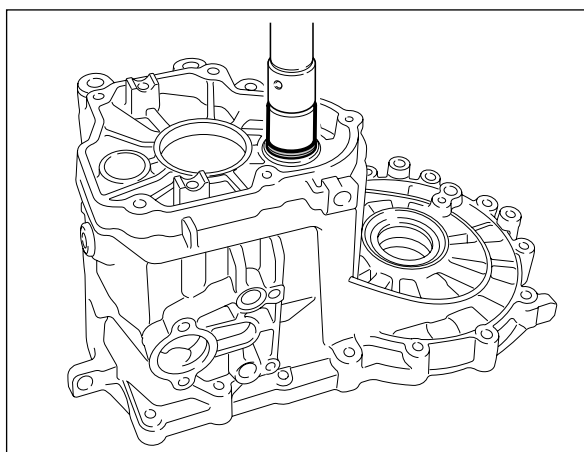

Fig. 50

- Remove both differential bearings

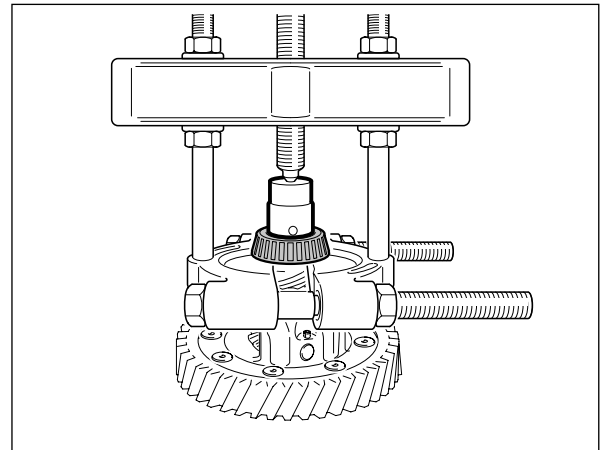

Fig. 51

- Press on the new differential bearings (1) on both sides

Note:

The inner and the outer rings of all tapered roller bearings are matched and must not be mixed up. All tapered roller bearings are force-fitted over the bearing inner ring using a suitable sleeve.

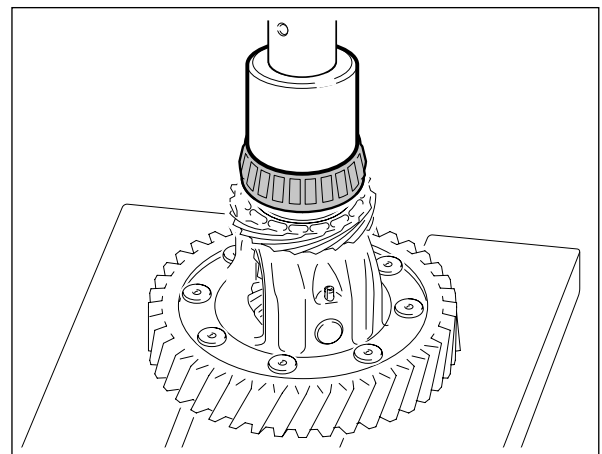

Fig. 52

- Press in the new outer ring (1) on the clutch housing side

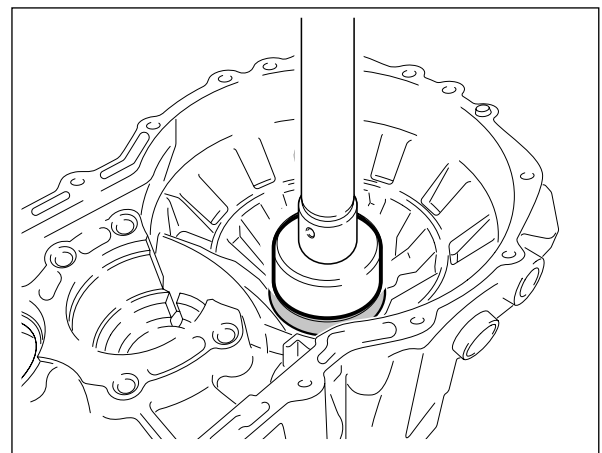

Fig. 53

- Press in the new outer ring (1) on the transmission housing side without a shim

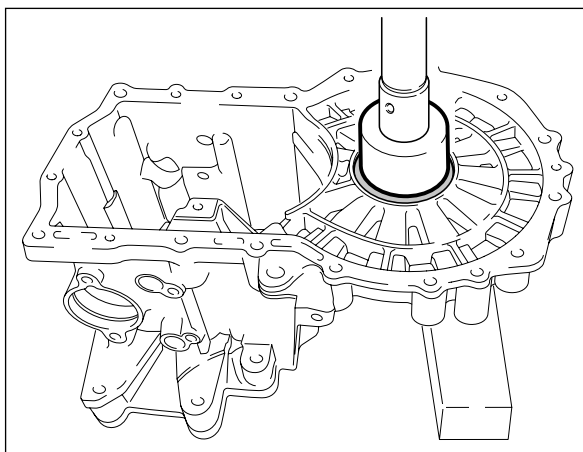

Fig. 54

- Press off the drive shaft bearing

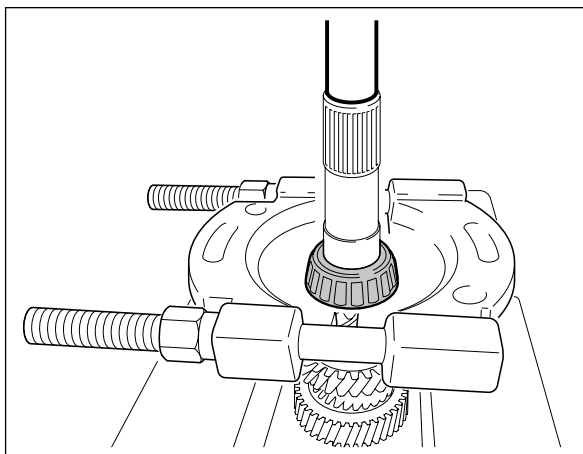

Fig. 55

- Press off the second drive shaft bearing along with the toothed gear for 4th gear, washer and sleeve

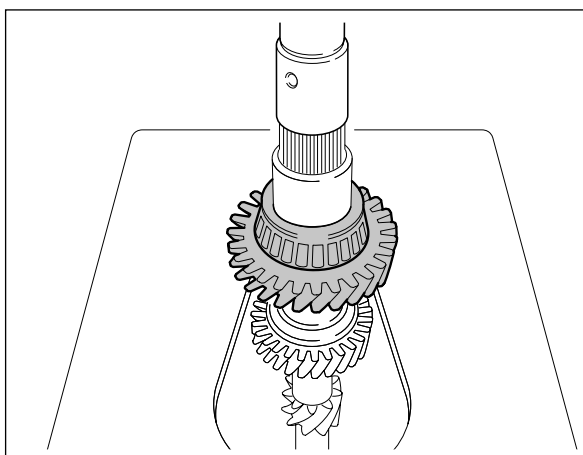

Fig. 56

- Press on the new drive shaft bearing (5)

Note:

Support the bearing when pressing on the inner ring.

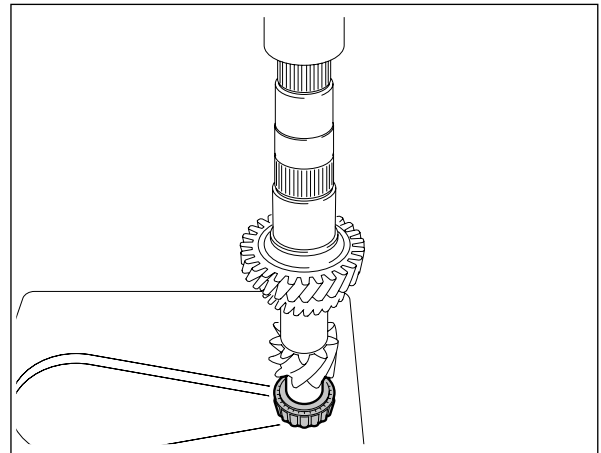

Fig. 57

- Press on 4th gear

Note:

The collar on the toothed gear must face towards 3rd gear.

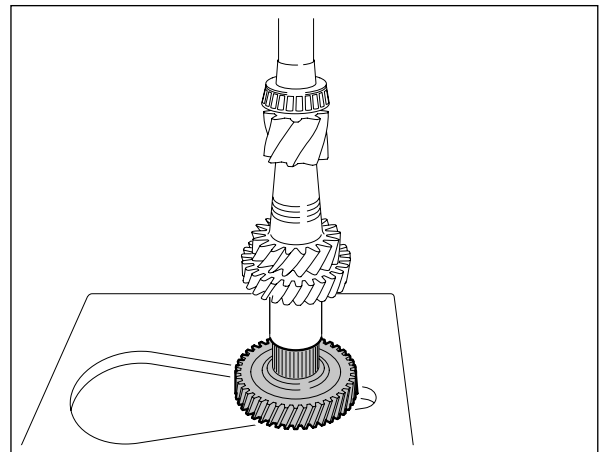

Fig. 58

- Press on the new drive shaft bearing (3) using a suitable press sleeve

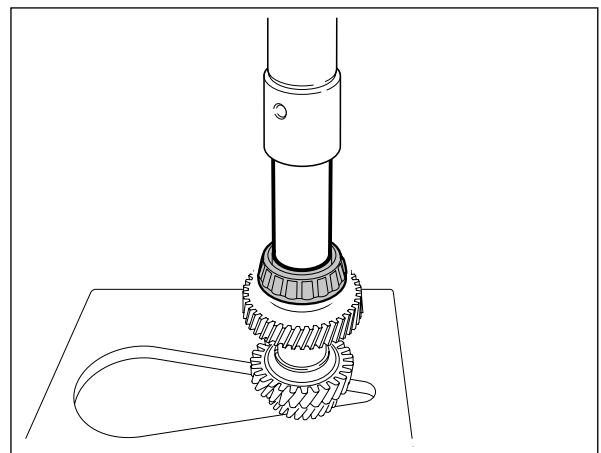

Fig. 59

- Position washer [1]
- Press the needle roller bearing sleeve [2] using a suitable press sleeve

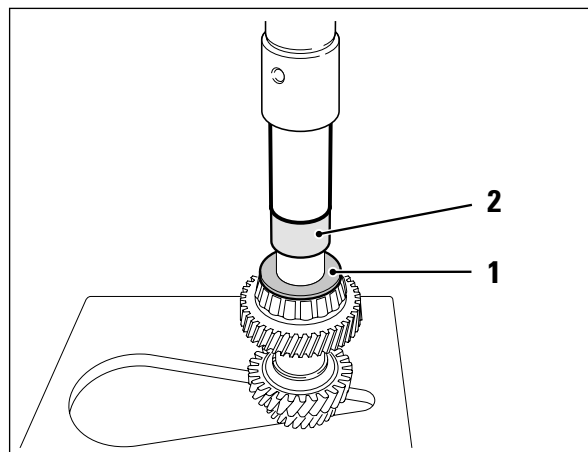

Fig. 60

- Press off the idlers for 2nd to 4th gears from the output shaft along with the synchro and sleeve [components 1–17]

Note:

Before disassembly, mark the position of the sliding sleeve relative to the synchro. Lift the components together when disassembling to prevent the synchro units from falling apart.

- Remove snap ring [18]

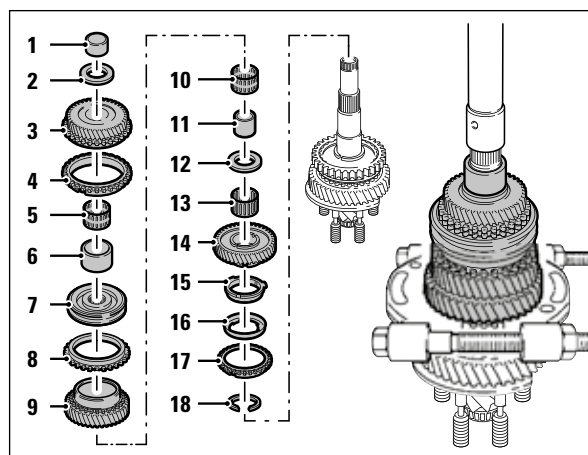

Fig. 61

- Press components [19-23] off the output shaft over the bearing seat [24]

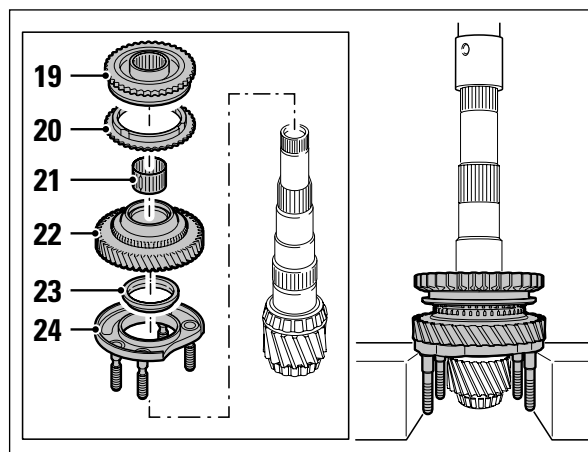

Fig. 62

- Press off the output shaft bearing on the transmission housing side

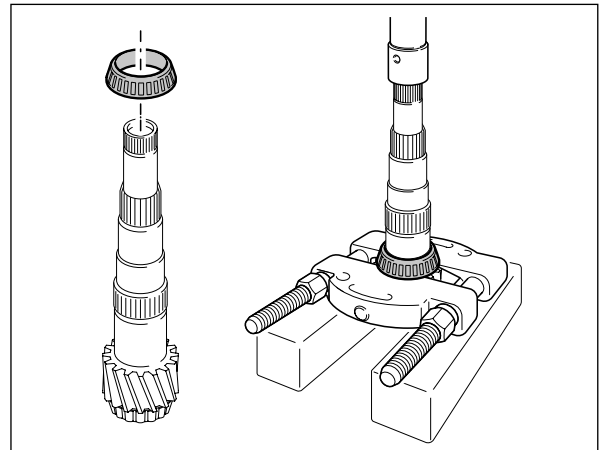

Fig. 63

- Press off the output shaft bearing on the clutch housing side

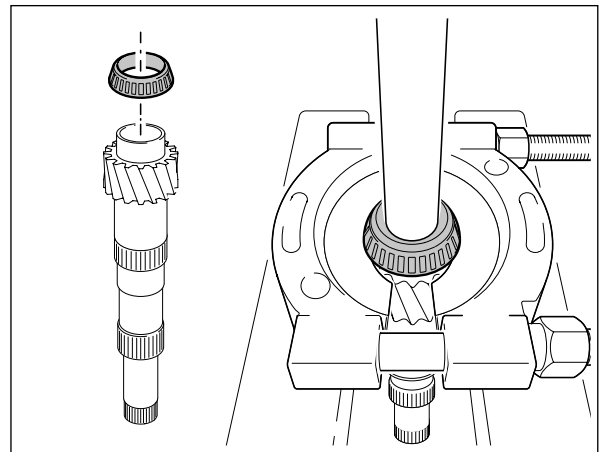

Fig. 64

- Press on the new bearing (4) over the inner ring on the output shaft

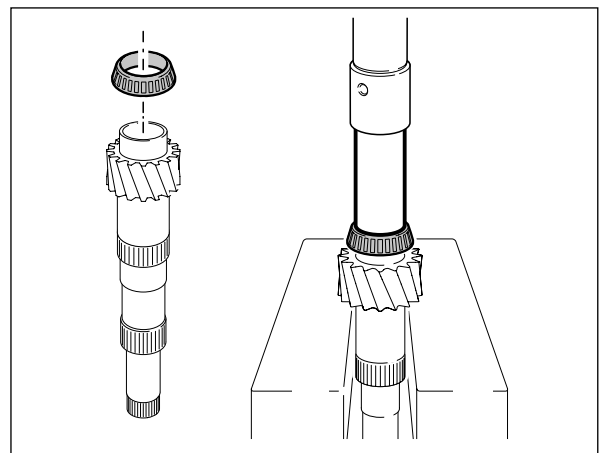

Fig. 65

- Press on the new bearing (2) [25] on the output shaft

Note:

Position the thrust washer [23] before force-fitting.

The step points towards the inner ring.

Use press sleeve (A).

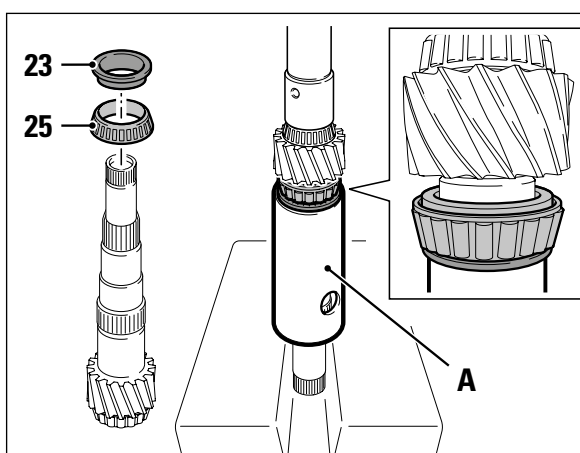

Fig. 66

- Press out the outer bearing ring from the bearing seat

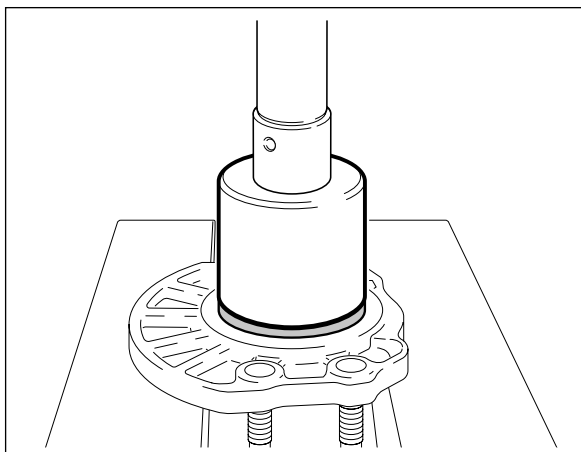

Fig. 67

- Press the outer ring of the new bearing (2) into the bearing seat

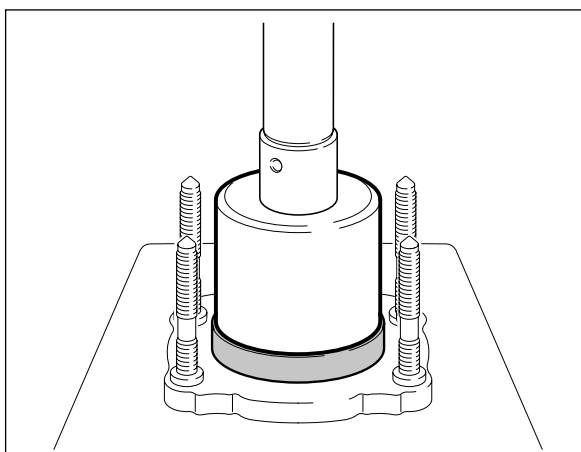

Fig. 68

- Press the new outer ring of the output shaft bearing (4) on the clutch housing side along with a 0.65-mm shim

Note:

Required for subsequent output shaft adjustment.
Use press sleeve (A).

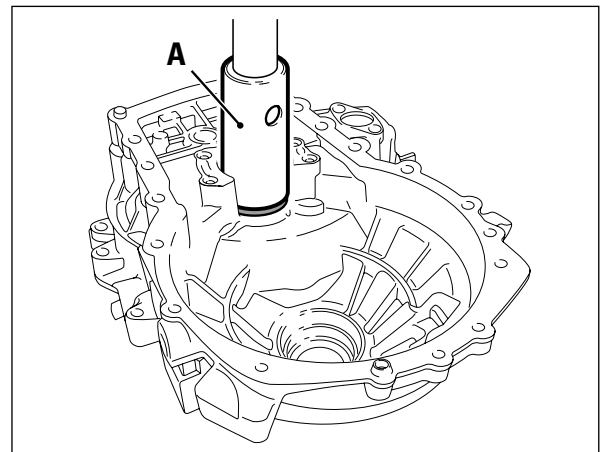

Fig. 69

- Press the new outer ring of the drive shaft bearing (5) on the clutch housing side using the press sleeve (A)

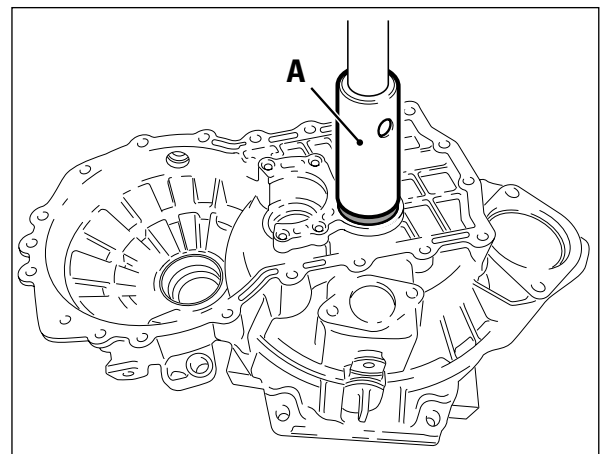

Fig. 70

- Press the new outer ring of the drive shaft bearing (3) on the transmission housing side without a shim

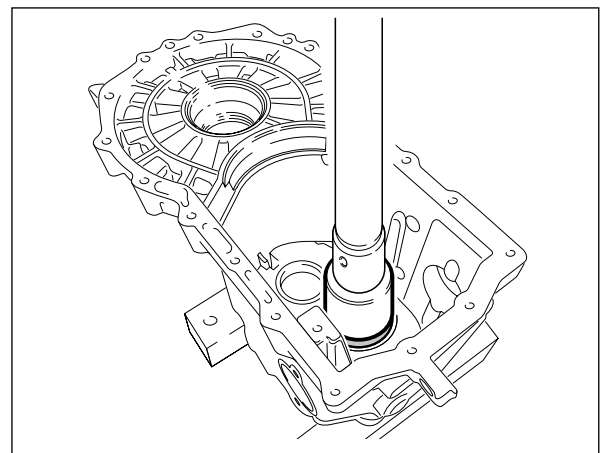

Fig. 71

- Press the new roller sleeve (6) or (7) for the output shaft

Note:

Follow the non-verbal installation instructions 999 6006 720 (leaflet included with LuK gearbox).

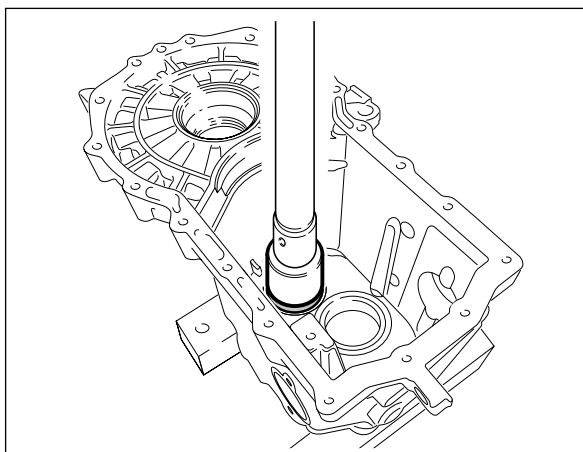

Fig. 72

- Secure the roller sleeve in the transmission housing with three centre punch marks

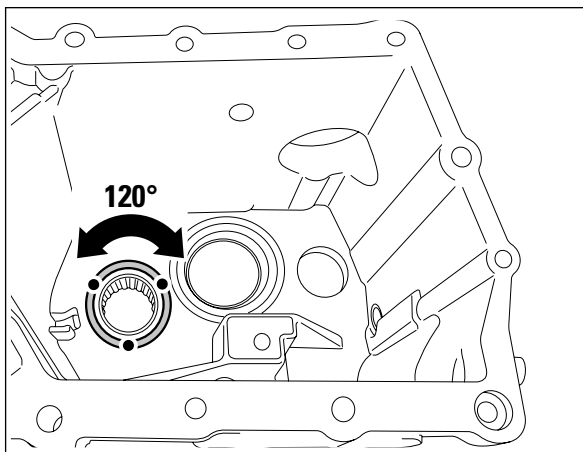

Fig. 73

- Insert the differential
- Attach the transmission housing

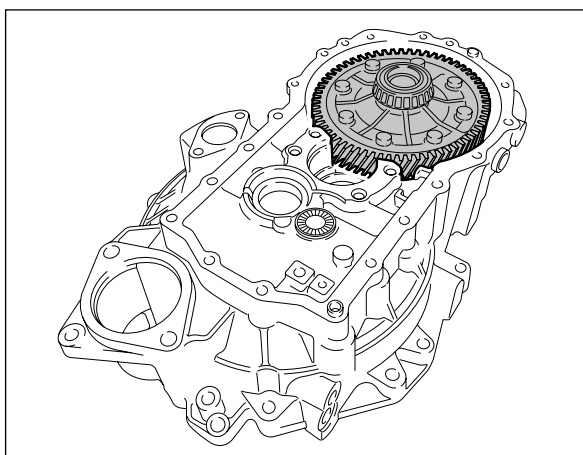

Fig. 74

- Fix transmission housing in place with the screws shown
Tightening torque: 25 Nm

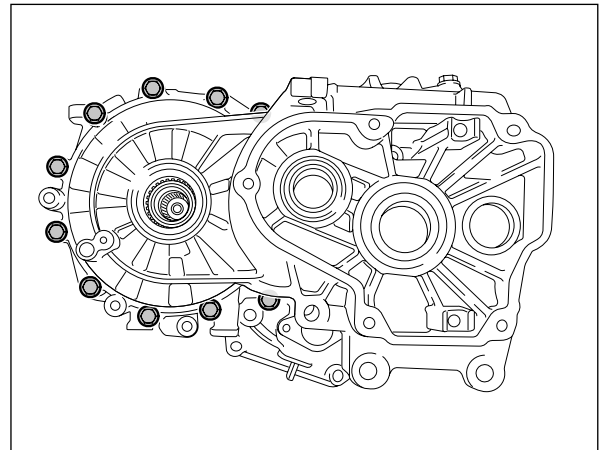

Fig. 75

- Assemble the dial gauge as shown and set to 0 with a 1-mm preload
- Move the differential up and down, reading the clearance as you do so
- The measured value + 0.40 mm shows the necessary shim thickness.

Example:

Measured value	0.70 mm
Preload (constant value)	+0.40 mm
<hr/>	
Shim	1.10 mm

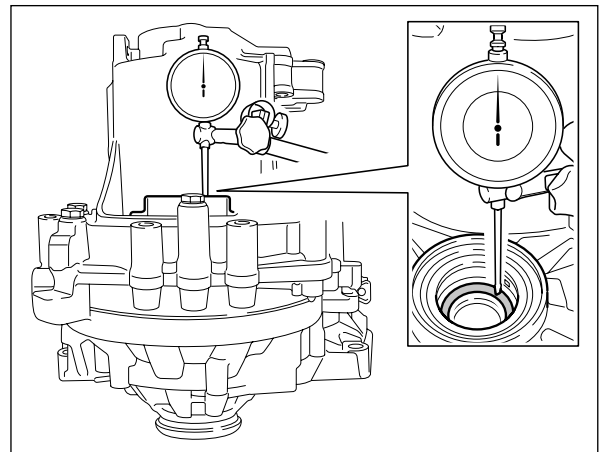

Fig. 76

- Remove transmission housing
- Pull out the outer ring of the differential bearing on the transmission housing side
- Insert a suitable shim and press the outer ring again

Note:

If the measured disc thickness is larger than the thickest disc from the differential shim kit, two washers that together form the required thickness can be installed.



Fig. 77

- Insert output shaft
- Tighten nuts for bearing seat (see page 14, figure 39)
Tightening torque: 25 Nm + 90°
- Assemble the dial gauge as shown and set to 0 with a 1-mm preload
- Move the output shaft up and down, reading the clearance as you do so

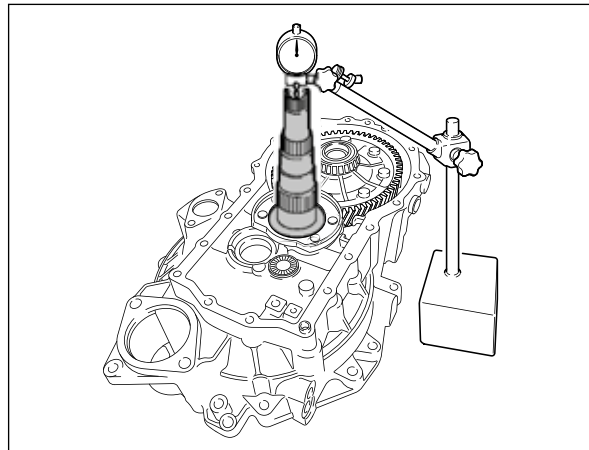

Fig. 78

The required thickness of shim is derived from:
Thickness of the disc inserted for measurement (0.65 mm) + clearance measured (figure 78) + 0.20 mm preload (constant value).

- Remove output shaft
- Pull out the outer ring of the output shaft bearing on the clutch housing-side
- Remove the 0.65 mm shim
- Insert the new, calculated shim
- Press in the outer ring again



Fig. 79

- Insert the drive shaft into the clutch housing
- Put the transmission housing together and fasten all screws
Tightening torque: 25 Nm + 90°
- Turn the drive shaft to settle the tapered roller bearings

Note:

This procedure must be repeated for each further measurement.

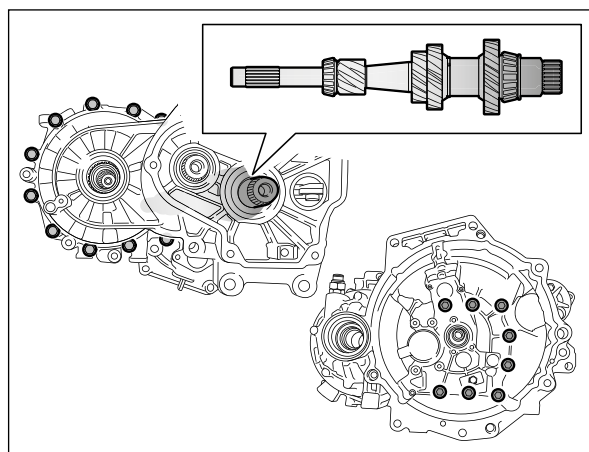

Fig. 80

- Assemble the dial gauge as shown and set to 0 with a 1-mm preload
- Move the drive shaft in the direction of the arrow, reading off the clearance as you do so
- Determine the correct shim using the table (page 42/43)

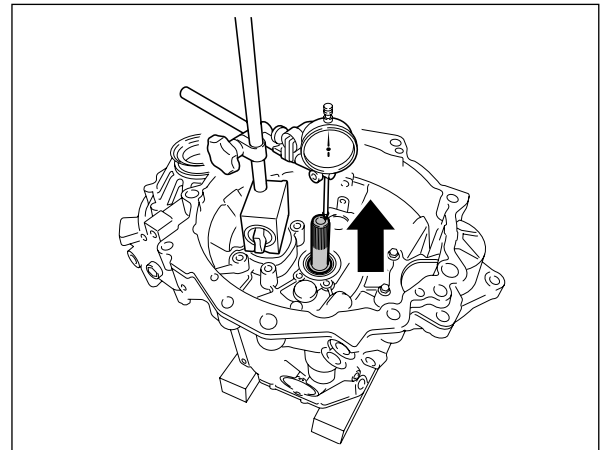

Fig. 81

- Remove drive shaft
- Pull out the outer ring of the drive shaft bearing on the transmission housing side
- Insert a suitable shim and press in the outer ring again
- Repeat the measuring procedure using a force-fit shim. The bearing play should be between 0.01 mm and 0.09 mm

Note:

If no more bearing play can be measured, but the drive shaft has a perceptible tilting clearance, the setting is also OK!



Fig. 82

- Position bearing seat [24], idler for 1st gear [22], needle roller bearing [21] and synchro ring [20].
- Press on the synchro unit [19] using a press sleeve (B)
- Mount snap ring [18]

Note:

The shaft must be supported and must **not** be placed on the tapered roller bearings. The exploded drawing shows a single-cone synchroniser unit. For transmissions constructed from 02/05/2000, this has been replaced by a triple-cone synchro.

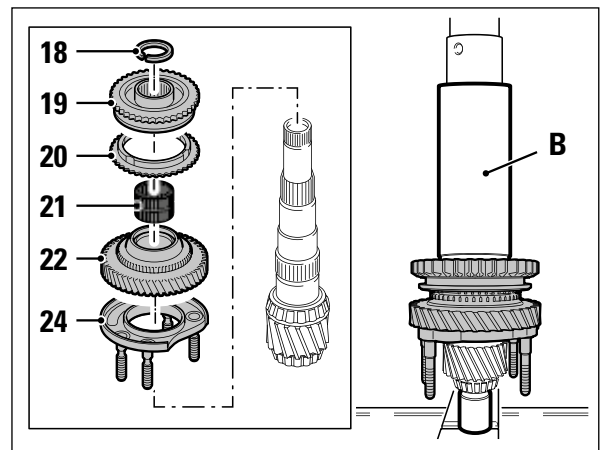

Fig. 83

- Position synchro rings [15–17], idler for 2nd gear [14], needle roller bearing [13] and thrust washer [12]
- Press on the sleeve for needle roller bearing for 3rd gear [11] onto the output shaft using a suitable press sleeve

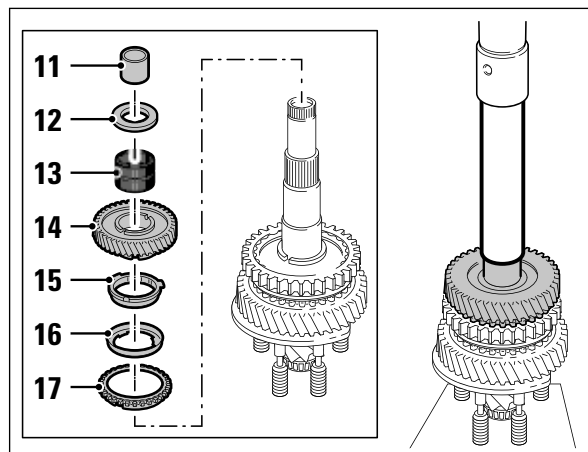

Fig. 84

- Position needle roller bearing [10], idler for 3rd gear [9] and synchro ring [8]
- Press on the synchro [7] onto output shaft using a press sleeve (B)

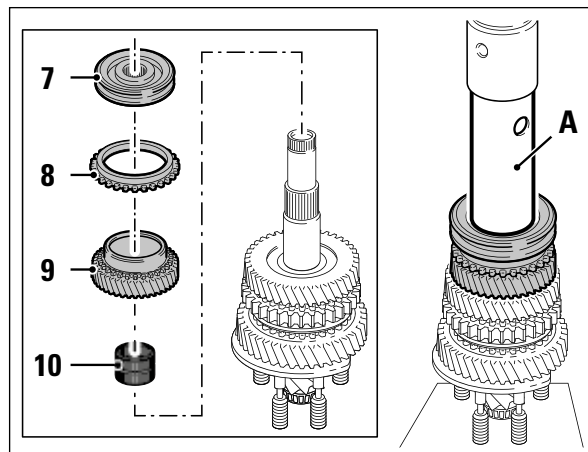

Fig. 85

- Press on the sleeve [6] for needle roller bearing for 4th gear onto the output shaft using a suitable press sleeve

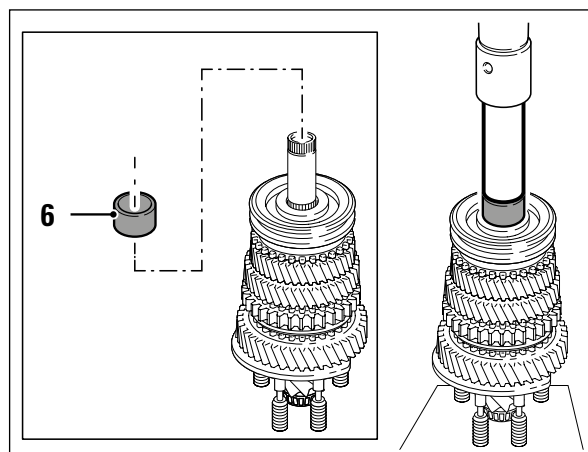

Fig. 86

- Position needle roller bearing [5], synchroniser ring [4], idler for 4th gear [3] and thrust washer [2]
- Press on the new sleeve (6) or (7) for needle roller bearing for 5th gear [1] onto the output shaft using a suitable press sleeve

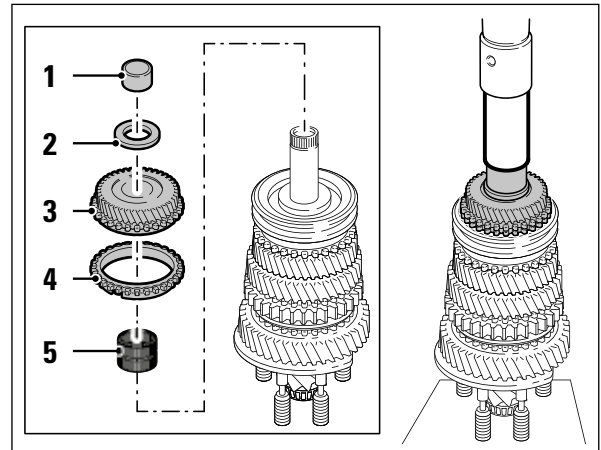

Fig. 87

- Replace the 4 bearing seat sealing rings (11)

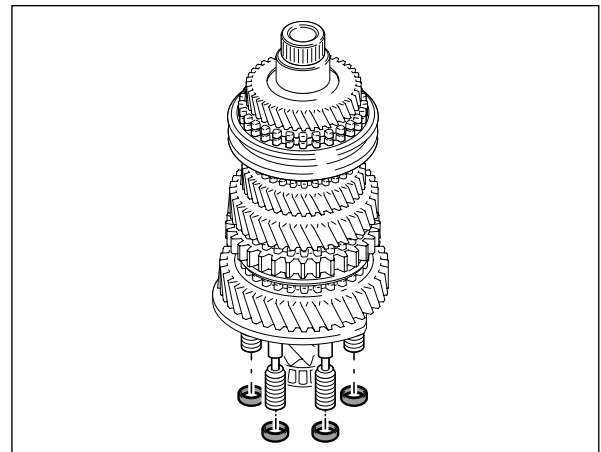

Fig. 88

- Fit the differential [1] and magnet [2]

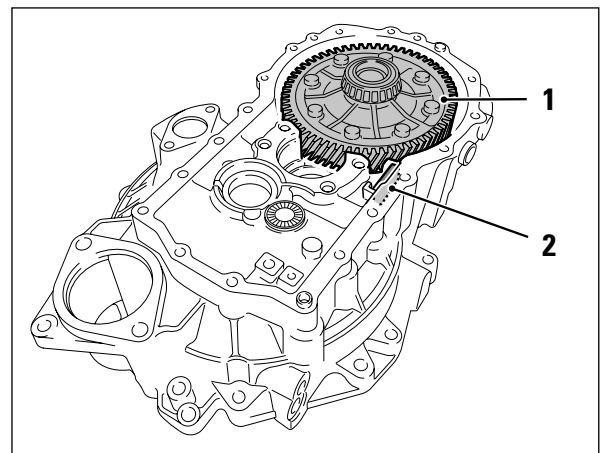

Fig. 89

- Insert drive shaft and output shaft together

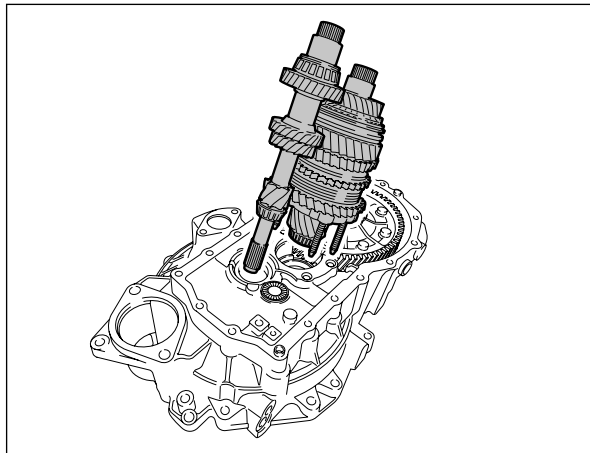

Fig. 90

- Tighten bearing seat nuts
Tightening torque: 25 Nm + 90°

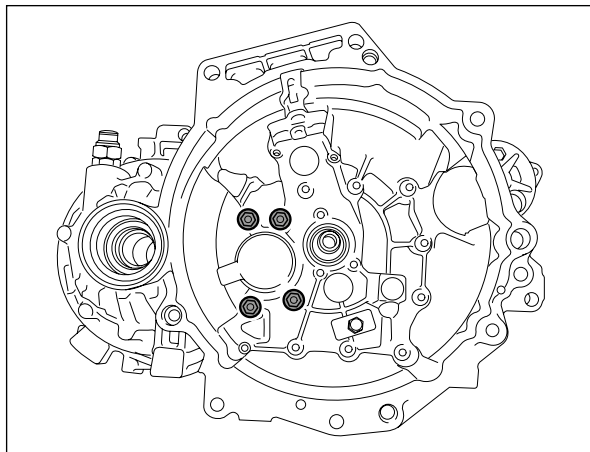

Fig. 91

- Position the reverse gear wheel

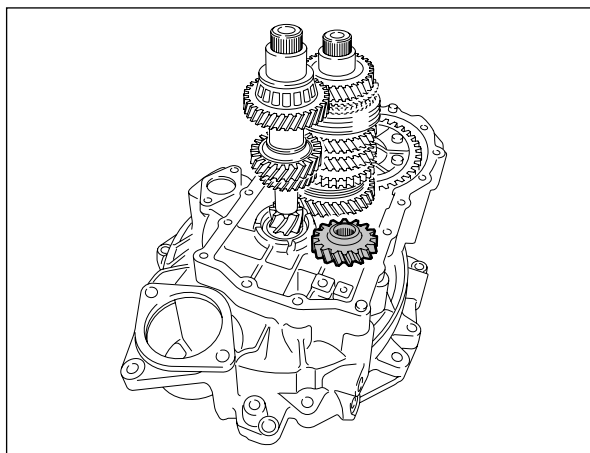

Fig. 92

- Install the reverse shaft with ratchet

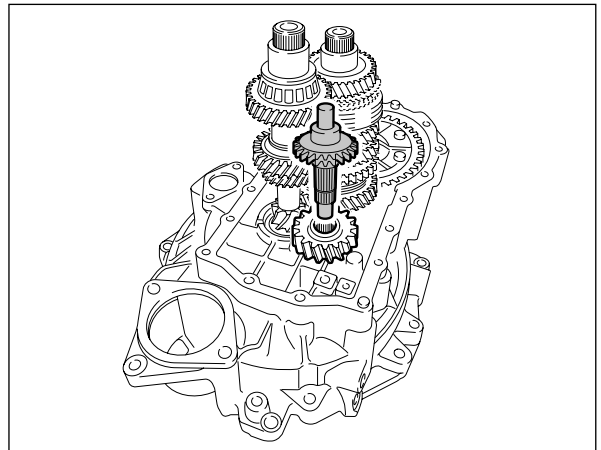

Fig. 93

- Attach the reverse shaft supports

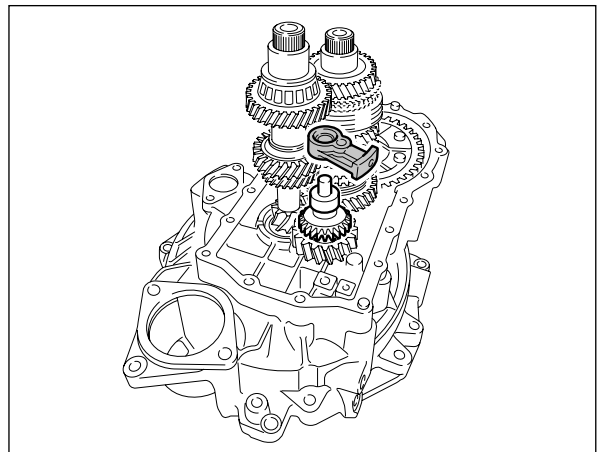

Fig. 94

- Screw in a M8 x 100-mm threaded rod

Note:

The stud bolt aligns the reverse shaft supports for later installation.

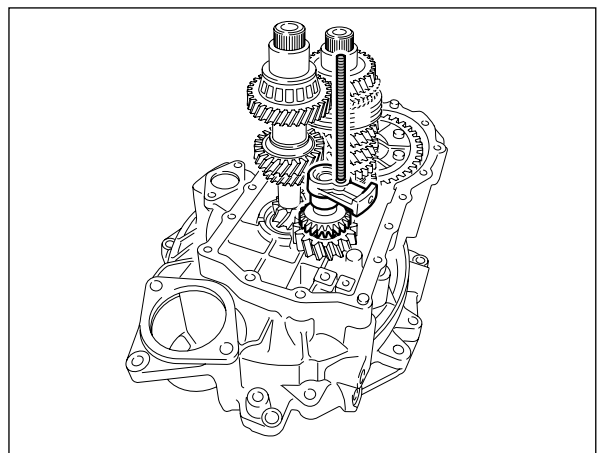

Fig. 95

- Assemble shift actuating mechanism for reverse gear
Tightening torque: 25 Nm

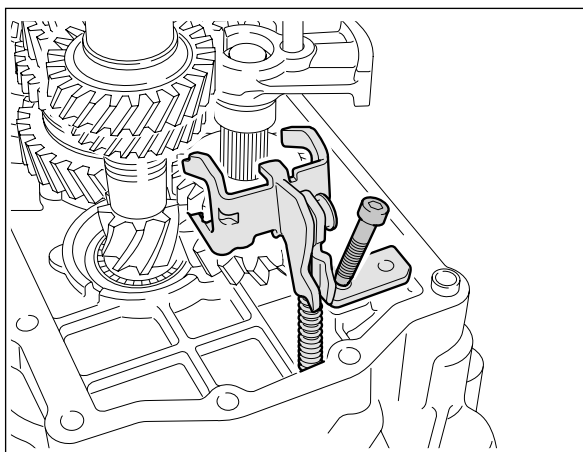

Fig. 96

- Insert gear selector forks and gear shift rails
- Align gear shift rails

Note:

The reverse gear selector fork must be aligned under the large shift fork (see detail photo).

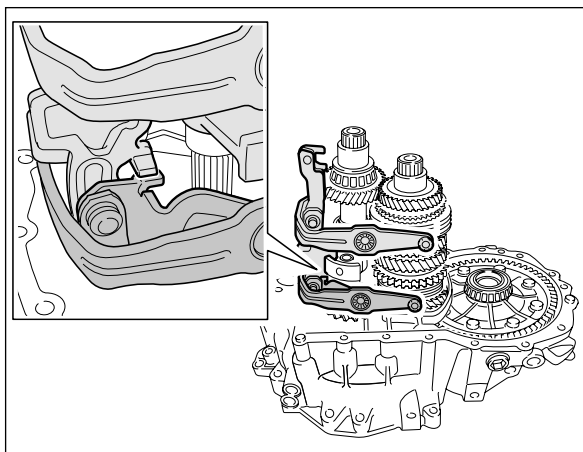

Fig. 97

- Clean the sealing surfaces
- Apply sealant evenly on the clutch housing

VW specification: AMV 188 200 03

Alternative: e.g. Corteco evo300

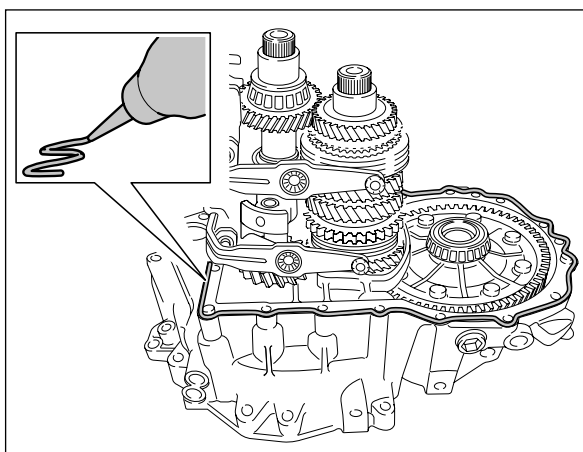

Fig. 98

- Attach the transmission housing

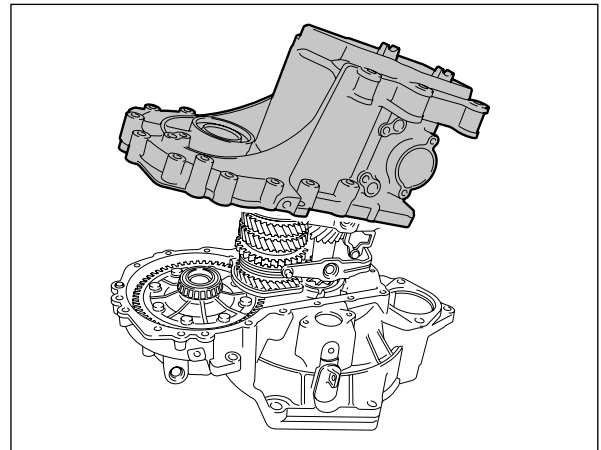

Fig. 99

- Tighten the housing screws
Tightening torque: 25 Nm + 90°
- Insert side screw [1] of reverse gear and tighten by hand
- Unscrew the threaded rod [2] and replace with original screw
- Tighten both screws one after the other
Tightening torque: 30 Nm

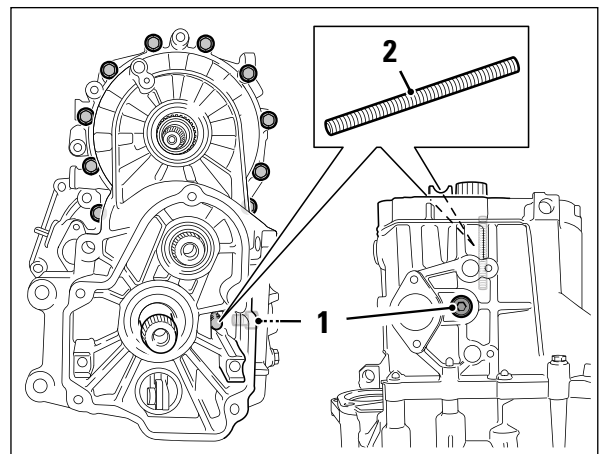

Fig. 100

- Install the housing bolts in the clutch bell
Tightening torque: 25 Nm + 90°

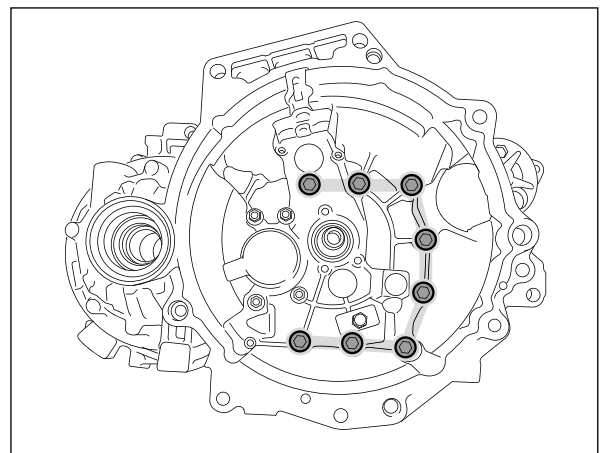

Fig. 101

- Clean the four bearing journals of the gear shift forks
- Replace O-rings (10) on the bearing journals

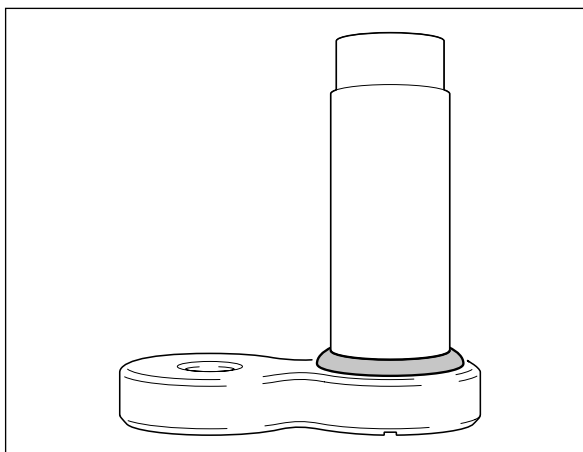

Fig. 102

- Install the four bearing journals
- Tightening torque: 25 Nm

Note:

If necessary, use a screwdriver to align the shift actuating mechanism.

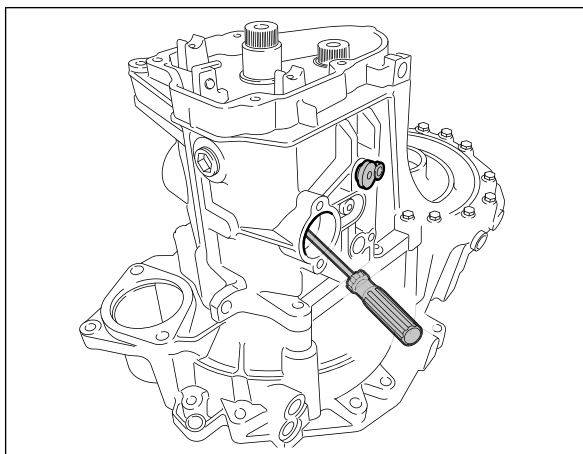

Fig. 103

- Clean the sealing surface
- Apply sealant evenly on the transmission housing

VW specification: AMV 188 200 03

Alternative: e.g. Corteco evo300

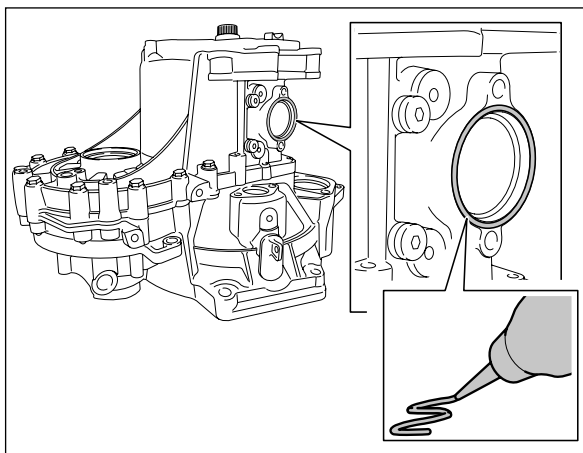

Fig. 104

- Put gear shift selectors into idle position
 - Insert lug [1] into the recess [2] of the transmission housing. Arrange gearshift shaft so that the shift finger [3] can be inserted into the gear shift rails
 - Install shift actuating mechanism
- Tightening torque: 25 Nm

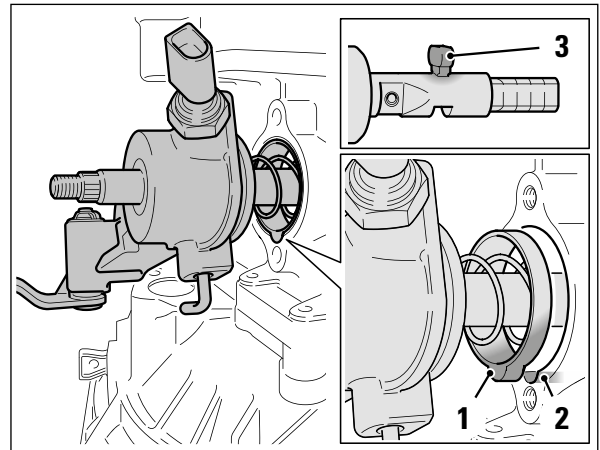

Fig. 105

- Install the gear change assembly weight
- Tightening torque: 25 Nm

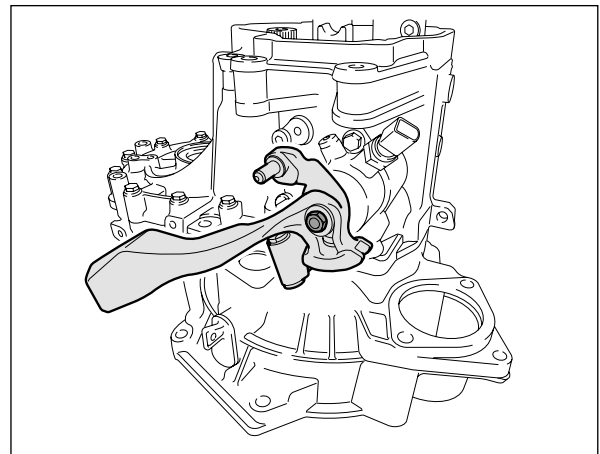

Fig. 106

- Install the bell crank [2]
- Engage the retaining clip [1]

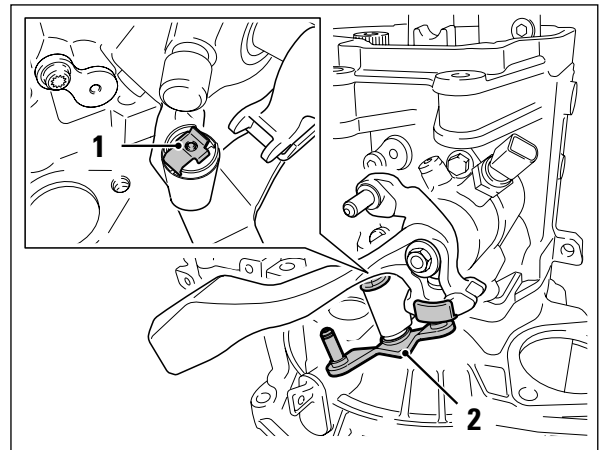

Fig. 107

- Clean the sealing surface
- Apply sealant evenly on the transmission housing.

VW specification: AMV 188 200 03

Alternative: e.g. Corteco evo300

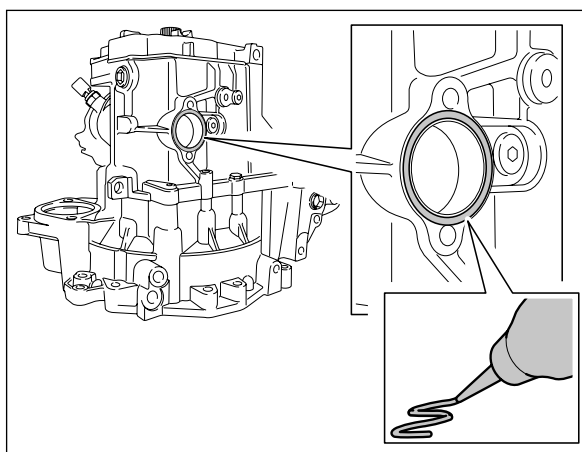

Fig. 108

- Install cover
- Tightening torque: 25 Nm

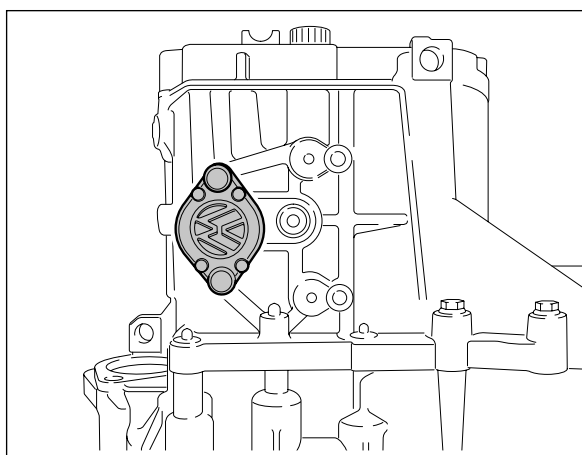

Fig. 109

- Press on 5th gear

Note:

Surrounding groove must point towards the transmission

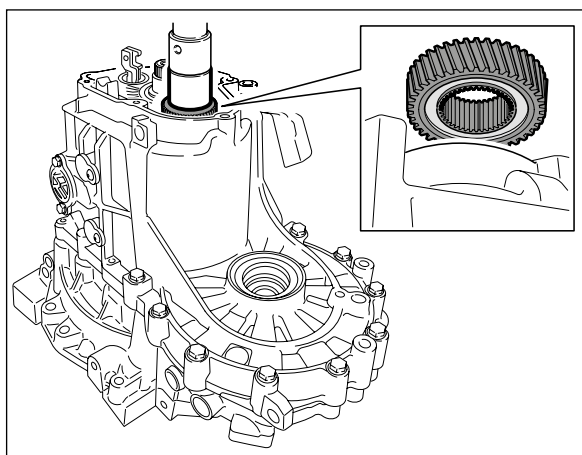

Fig. 110

- Engage needle roller bearing [1] and idler for 5th gear [2]

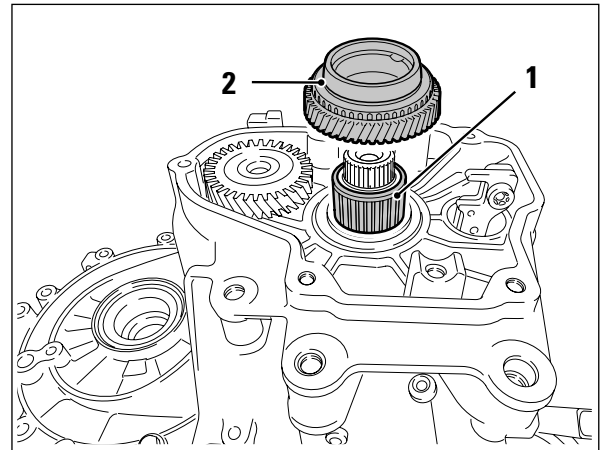

Fig. 111

- Press on the synchro unit for 5th gear along with the synchro ring

Note:

The cast-on catches of the synchro ring [1] must be seated in the recesses [2] of the synchro unit.

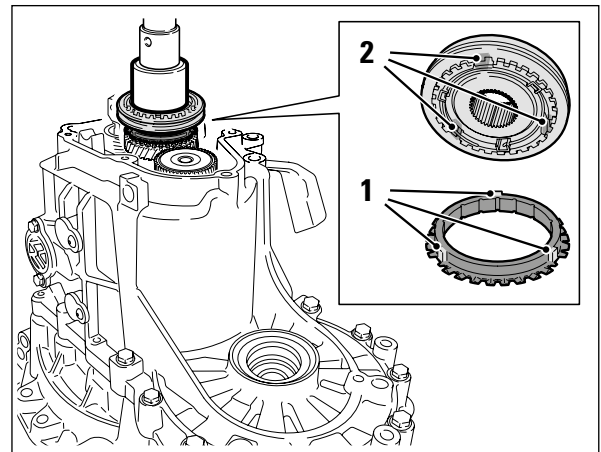

Fig. 112

- Press down shift collar for 5th gear [1], push in gearshift shaft [2] and rotate anti-clockwise [3]
- Position plate springs [4]
- Install screws [5] for synchro unit and 5th gear
- Tightening torque: 80 Nm
- Return the gearshift shaft and sliding sleeve for 5th gear to the neutral position

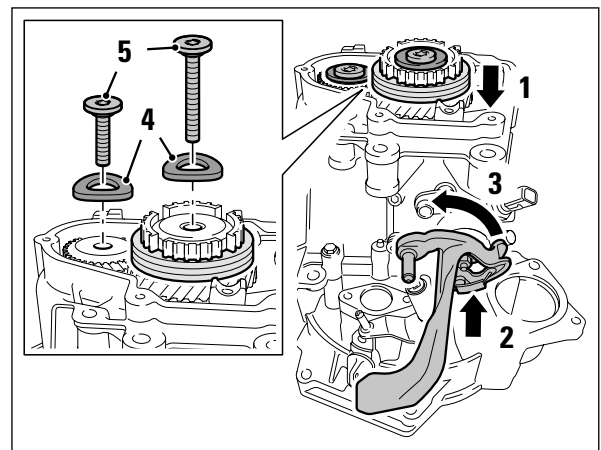

Fig. 113

- Install the selector fork and tighten screws [1]
Tightening torque: 25 Nm
- Engage 5th gear using the shift actuating mechanism
- Loosen screw [2]
- Push sliding sleeve and gearshift jaws downwards
- Tighten screw on gearshift jaws [2]
Tightening torque: 25 Nm

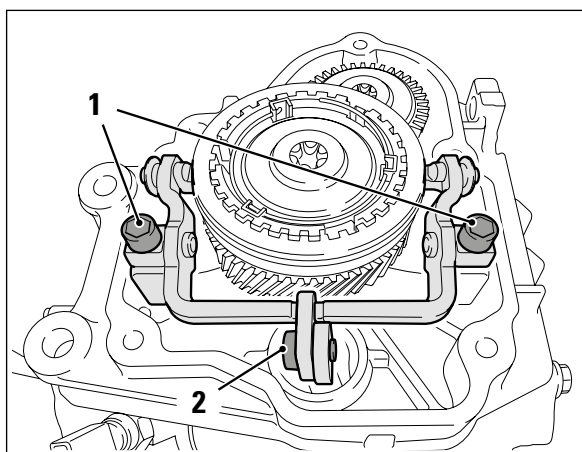

Fig. 114

- Perform control measurement: It must not be possible to insert a feeler gage of 0.2 mm between the sliding sleeve and ratchet
- Repeat the adjustment procedure if required
- Disengage 5th gear: The sliding sleeve must now be in the neutral position, synchro ring for 5th gear must move freely
- Shift through all gears

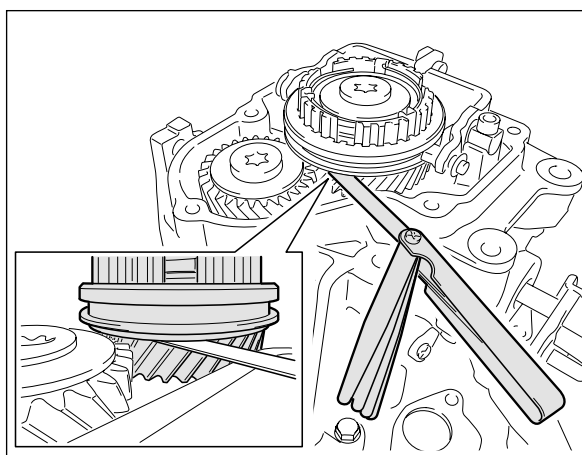

Fig. 115

- Replace the cover seal (14)

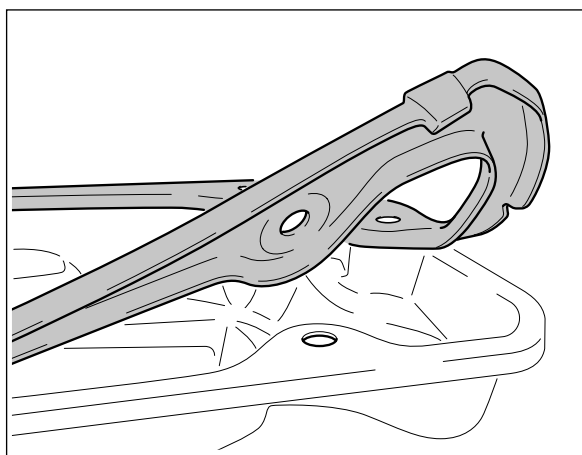

Fig. 116

- Install cover for gear housing
Tightening torque: 10 Nm

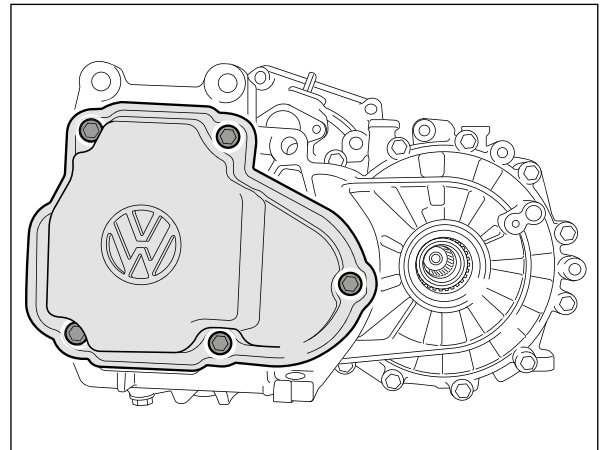

Fig. 117

- Install a new guide sleeve (13)
Tightening torque: 20 Nm
- Grease the sleeve around the release bearing

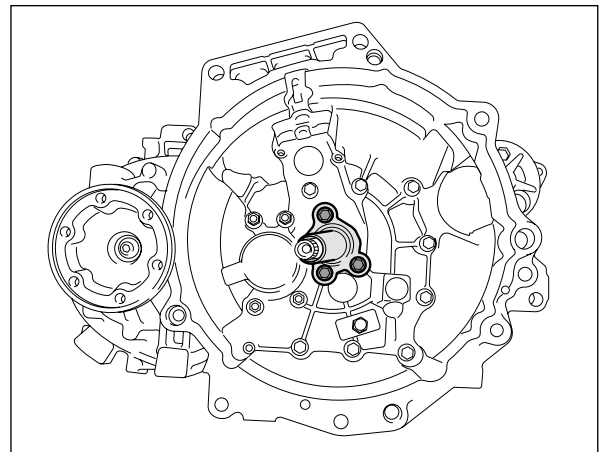

Fig. 118

- Fasten the retaining spring to the clutch release lever
- Install clutch release lever
- Hook in the retaining spring
- Grease the release bearing at the contact point with the release lever and push into place

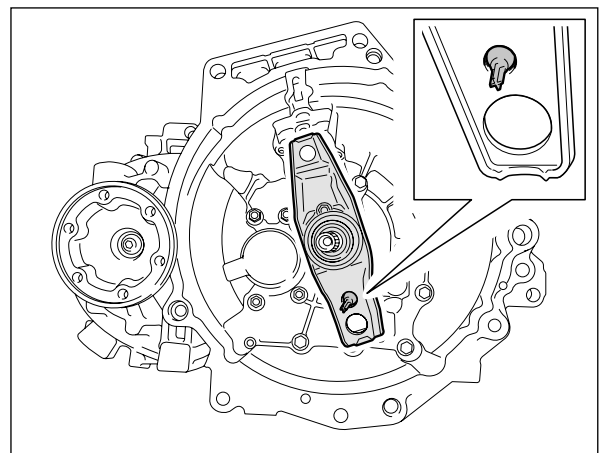

Fig. 119

- Install both flanged shafts with pressure springs, thrust washers and tapered rings
Tightening torque: 25 Nm

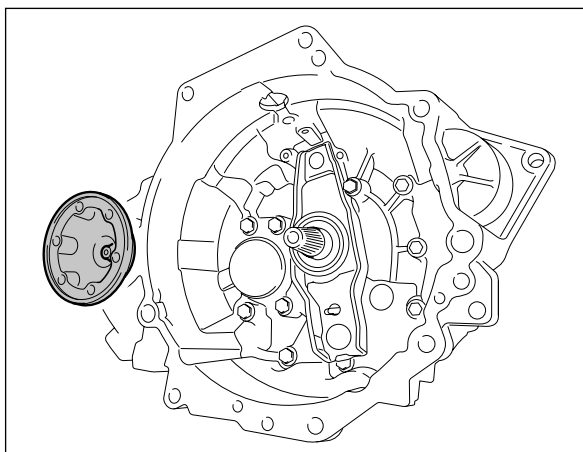

Fig. 120

- Install gearbox according to vehicle manufacturer's specifications
- Pour in gearbox oil according to vehicle manufacturer's specifications



Fig. 121

Setting the drive shaft tapered roller bearing – shim table

Part number for shim set: 464 0003 10

Bearing play	Shim	
Measured value (mm)	Thickness (mm)	VW spare part no.
0.671 ... 0.699	0.650	02A 311 140
0.700 ... 0.724	0.675	02A 311 140 A
0.725 ... 0.749	0.700	02A 311 140 B
0.750 ... 0.744	0.725	02A 311 140 C
0.775 ... 0.799	0.750	02A 311 140 D
0.800 ... 0.824	0.775	02A 311 140 E
0.825 ... 0.849	0.800	02A 311 140 F
0.850 ... 0.874	0.825	02A 311 140 G
0.875 ... 0.899	0.850	02A 311 140 H
0.900 ... 0.924	0.875	02A 311 140 J
0.925 ... 0.949	0.900	02A 311 140 K
0.950 ... 0.974	0.925	02A 311 140 L
0.975 ... 0.999	0.950	02A 311 140 M
1.000 ... 1.024	0.975	02A 311 140 N
1.025 ... 1.049	1.000	02A 311 140 P
1.050 ... 1.074	1.025	02A 311 140 Q
1.075 ... 1.099	1.050	02A 311 140 R
1.100 ... 1.124	1.075	02A 311 140 S
1.125 ... 1.149	1.100	02A 311 140 T
1.150 ... 1.174	1.125	02A 311 140 AA
1.175 ... 1.199	1.150	02A 311 140 AB
1.200 ... 1.224	1.175	02A 311 140 AC
1.225 ... 1.249	1.200	02A 311 140 AD
1.250 ... 1.274	1.225	02A 311 140 AE
1.275 ... 1.229	1.250	02A 311 140 AF
1.300 ... 1.324	1.275	02A 311 140 AG

Setting the drive shaft tapered roller bearing – shim table

Part number for shim set: 464 0003 10

Note: A combination of two shims is required for bearing play greater than 1.325 mm.

Bearing play	Shim	
Measured value (mm)	Thickness (mm)	VW spare part no.
1.325 ... 1.349	1.300	02A 311 140
		02A 311 140
1.350 ... 1.374	1.325	02A 311 140
		02A 311 140 A
1.375 ... 1.399	1.350	02A 311 140 A
		02A 311 140 A
1.400 ... 1.424	1.375	02A 311 140 A
		02A 311 140 B
1.425 ... 1.449	1.400	02A 311 140 B
		02A 311 140 B
1.450 ... 1.474	1.425	02A 311 140 B
		02A 311 140 C
1.475 ... 1.499	1.450	02A 311 140 C
		02A 311 140 C
1.500 ... 1.524	1.475	02A 311 140 C
		02A 311 140 D
1.525 ... 1.549	1.500	02A 311 140 D
		02A 311 140 D
1.550 ... 1.574	1.525	02A 311 140 D
		02A 311 140 E
1.575 ... 1.599	1.550	02A 311 140 E
		02A 311 140 E
1.600 ... 1.624	1.575	02A 311 140 E
		02A 311 140 F
1.625 ... 1.649	1.600	02A 311 140 F
		02A 311 140 F
1.650 ... 1.674	1.625	02A 311 140 F
		02A 311 140 G
1.675 ... 1.699	1.650	02A 311 140 G
		02A 311 140 G
1.700 ... 1.724	1.675	02A 311 140 G
		02A 311 140 H
1.725 ... 1.749	1.700	02A 311 140 H
		02A 311 140 H
1.750 ... 1.774	1.725	02A 311 140 H
		02A 311 140 J
1.775 ... 1.791	1.750	02A 311 140 J
		02A 311 140 J

More garage knowledge:
www.rexpert.com