



NEWS

**HD Transmissions
Systems**

Part number

830117

Application for
**Renault Trucks & Volvo
Trucks Euro 5 & 6**

SPECIFICITY OF THE VALEO CONCENTRIC PNEUMATIC ACTUATOR

VALEO PCA

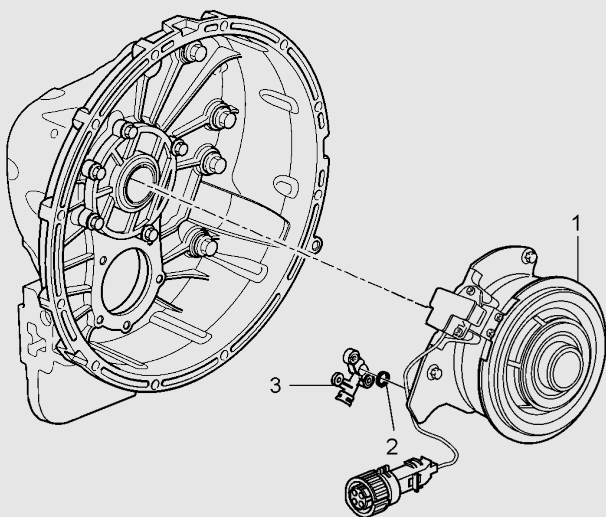

- In order to ease the work of the mechanic, the **Valeo pneumatic concentric actuator (1)** is supplied with the **seal (2)** and the **air inlet (3)** pre-installed.
- **already bolted on the product, bolts being tighten at the right torque.**
- This **saves time** for the mechanic when fitting the PCA to the gearbox as the connector might get damaged when dismantling the product.
- **The gasket** which must be replaced together with the pneumatic concentric actuator, is **already fitted inside the connector.**
- After fitting the PCA to the gearbox, the mechanic just has to plug the connector to the air hose with the lock brace
- This air connector is specific for the **Renault Trucks - Volvo Trucks Euro 5 & Euro 6 applications with Automated Manual Transmission (AMT)**

