



## BLUE dynamic

### Vehicle Keybenefit



Engineered to the highest German standards



Patented PowerFrame® grid for reliable starting power, fast recharge and corrosion resistance



Meets all original criteria of the car manufacturer

For more information visit [varta-automotive.com](http://varta-automotive.com)

### ORDER INFORMATION

European Type No. (ETN):	544402044
Article Number:	5444020443132
Short Code:	B18
Barcode:	4016987119495
UK Code:	063
Packaging Unit:	1
Quantity per Pallet:	72

### TECHNICAL INFORMATION

Voltage [V]:	12	Base Hold-down:	B13
Battery Capacity [Ah]:	44	Layout:	0
Cold Cranking Amps (CCA), EN [A]:	440	Terminal Types:	1
Length [mm]:	207	Case Size:	T4/LBN1
Width [mm]:	175	Weight filled (kg):	11,29
Height [mm]:	175		

# DRAWINGS

**B13**

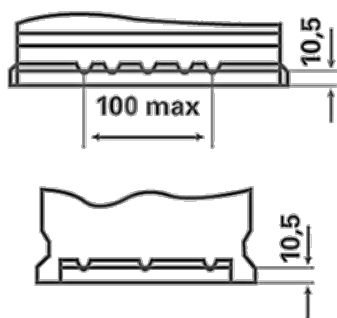

**0**

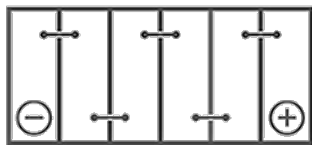

**1**



ø 19,5  
H 18



ø 17,9  
H 18



pos.



neg.