



BLACK dynamic

Vehicle Keybenefit



Engineered to the highest German standards



Patented PowerFrame® grid for reliable starting power, fast recharge and corrosion resistance



Fulfills requirements of the OE as a matching spare part

For more information visit varta-automotive.com

ORDER INFORMATION

European Type No. (ETN):	570144064
Article Number:	5701440643122
Short Code:	E9
Barcode:	4016987119433
UK Code:	100
Packaging Unit:	1
Quantity per Pallet:	48

TECHNICAL INFORMATION

Voltage [V]:	12	Base Hold-down:	B13
Battery Capacity [Ah]:	70	Layout:	0
Cold Cranking Amps (CCA), EN [A]:	640	Terminal Types:	1
Length [mm]:	278	Case Size:	T6/LBN3
Width [mm]:	175	Weight filled (kg):	16,00
Height [mm]:	175		

DRAWINGS

B13

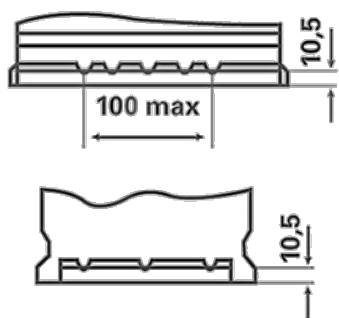

0



1



ø 19,5
H 18



ø 17,9
H 18



pos.



neg.