

75

TECHNICAL REPORT

Selection of cylinder head
gasket and rocker cover for
Mercedes engines OM501 /
OM502



PURPOSE

Indicate the **main differences between cylinder head gaskets and rocker cover** of OM501 & OM502 Engines in Mercedes-Benz Actros

DEVELOPMENT

OM501 & OM502 engines family, with 6 and 8 cylinders, uses similar cylinder head gasket and rocker cover with some modifications which make them not to be interchangeable. For this,

Ajusa has all the references and combinations among them for this type of engines.

The type of gaskets that each vehicle uses, **depends on the manufacturing engine number.** The relation is shown in the following table:

ENGINE TYPE	Cylinder Head Gasket	Rocker Cover Gasket
OM501, OM502 hasta nº 084423	10132700	11083300
OM501, OM502 desde nº 084424 hasta nº 155295	10132700	11083400
OM501, OM502 desde nº 155296 hasta nº 357749	10132700	11103000
OM501, OM502 desde nº 357749	10183400	11103000

The customer can check the information of their vehicle, engine manufacturing number included, in the following parts of the engine or chassis:



Sometimes is common not knowing what engine number the vehicles have, so the purpose of this TIP is **to help Ajusa customers to choose the correct gasket set**, making a comparison among them.

All sets have been **developed using the same manufacturing process** and same quality; the differences, as can be seen, are in the design of the gaskets.

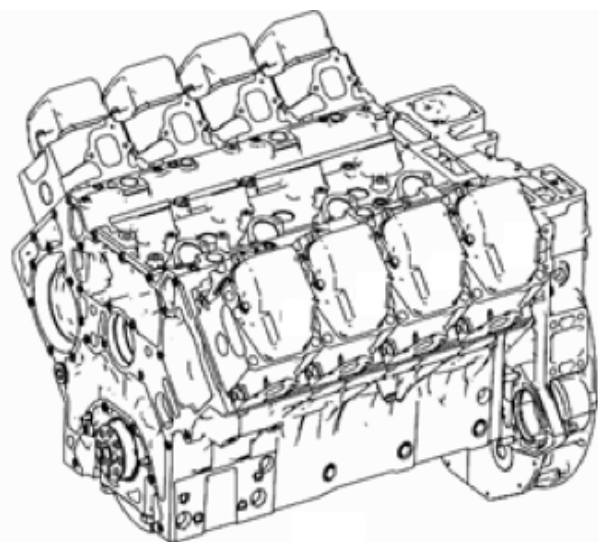

➤ DIFFERENCE BETWEEN ROCKER COVER GASKET

11083300

11083400

11103000

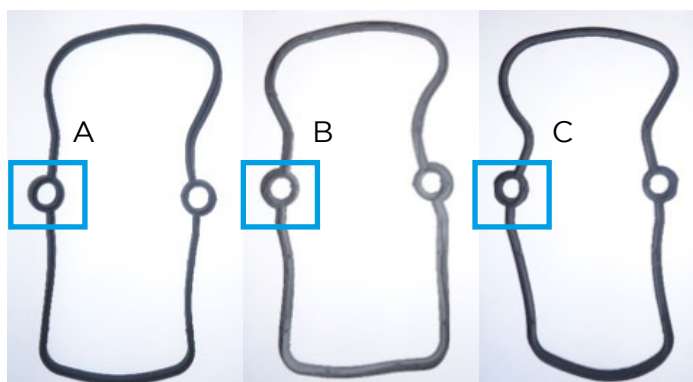

A

B

C

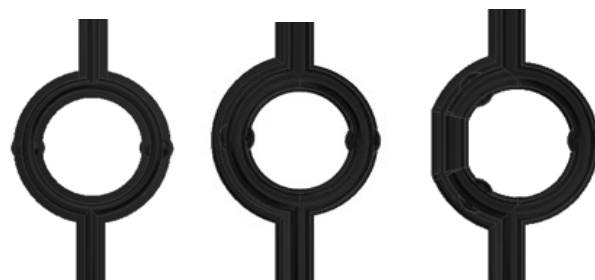

➤ **DIFERENCIA ENTRE CILINDRO HEAD GASKET**

10132700

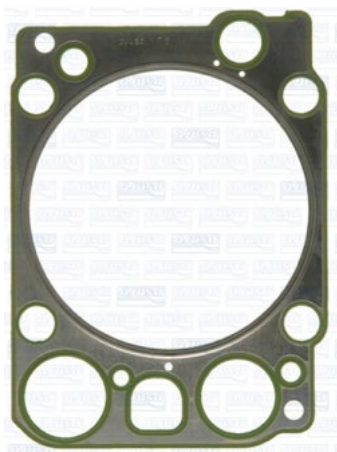

10183400

