

Boletim técnico

PSA & FIAT IVECO F1CE3481N/D/E (F30DT)

TCK194C vs. TCK194LC

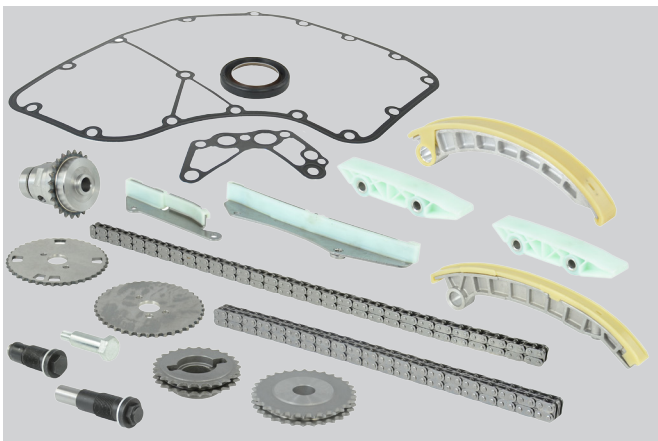

TCK194C

Número do motor para: 1442629 e até o padrão de emissão: Euro IV inclui TCK194NG e TCK195NG

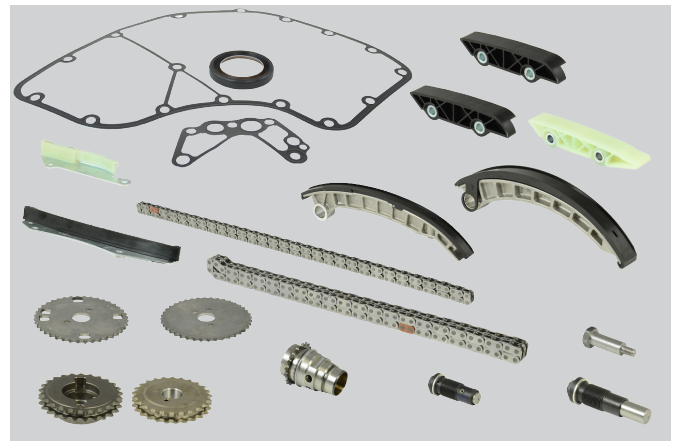

TCK194LC

Número do motor de: 1442630 e do padrão de emissão Euro V inclui TCK194LNG e TCK195LNG

Posição de montagem: superior

TCK194NG - Número do motor: 1442629 e padrão de emissão: Euro IV

TCK194LNG - Número do motor: 1442630 e padrão de emissão Euro V

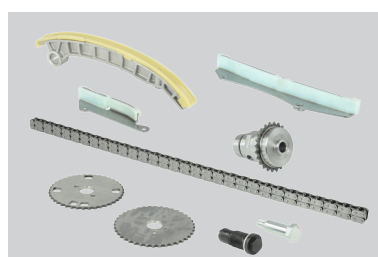

TCK194NG: Corrente: Simplex, Link Fechado, **122** Links

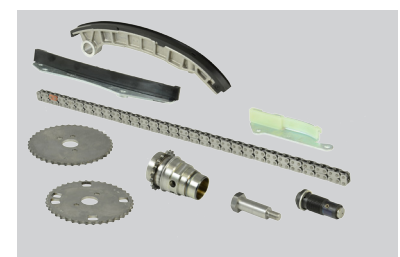

TCK194LNG: Corrente: Simplex, Link Fechado, **120** Links

Nota: O design da roda dentada da bomba de injeção no **TCK194LNG** mais recente é diferente devido à corrente ser mais curta.



Best Availability. Best Value.
Best Quality. Best Service.

TB0002-1



Boletim técnico

PSA & FIAT IVECO F1CE3481N/D/E (F30DT)

TCK194C vs. TCK194LC

Posição de montagem: superior

TCK195NG - Número do motor: 1442629 e até padrão de emissão: Euro IV

TCK195LNG - Número do motor: 1442630 e do padrão de emissão Euro V

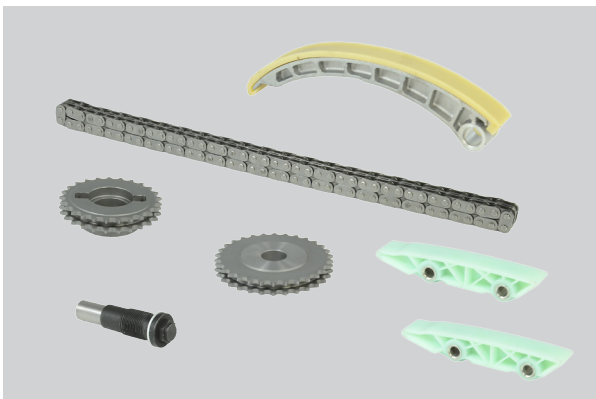

TCK195NG: Corrente: Duplex, Link Fechado, 84 Links



TCK195LNG: Corrente: Duplex, Link Fechado, 84 Links

Observação: As calhas guia e a engrenagem da cambota são diferentes.

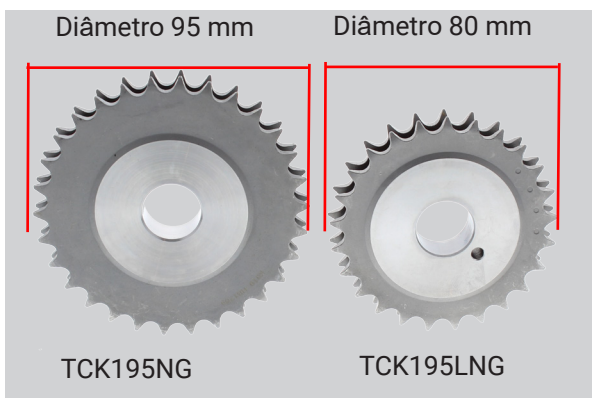

Engrenagem da Cambota



Calhas Guia



Best Availability. Best Value.
Best Quality. Best Service.

TB0002-1

