

**DTE-3007**

DKT-3004

DKW-3002 / DKW-3003 / DKW-3004

OEM References

2441027000

2441027250

**MODALITY OF ASSEMBLING AND TENSION-SETTING OF THE TENSIONER**

- Verify that timing marks **A** and **B** are lined up
- Assemble the new tensioner and the new idler
- Ensure that the tensioner is correctly positioned
- Assemble the timing belt anti-clockwise, starting from the crankshaft- pinion
- Slacken the bolt "a" (Fig. 1)
- Rotate the crankshaft 2 revolutions clockwise

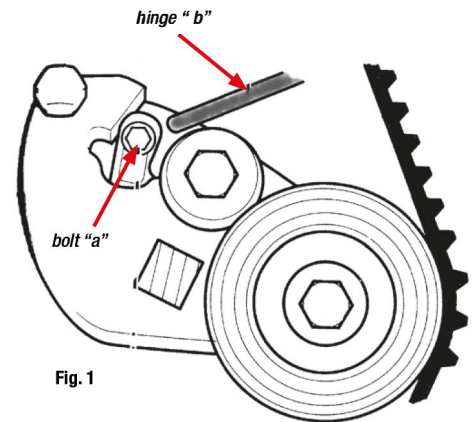
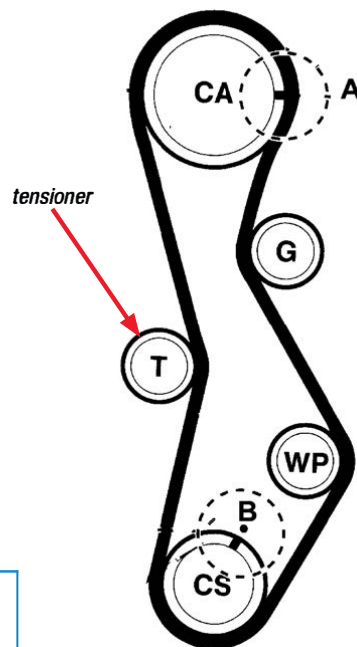

Fig. 1

- Verify that the timing marks **A** and **B** are lined up
- Block the bolt "a" (**10-12 Nm**)
- Unthread the hinge "b" (Fig. 1) from the base plate of the tensioner
- Re-install other removed parts
- Block the bolts of the crankshaft pulley (**50-55 Nm**)



Need more info?  
Check our website:  
[www.kavoparts.com](http://www.kavoparts.com)