

## CORRECT FITMENT

OC6316 - OC6317 - OC6322 - OC6325 - OC6326 - OC6335

BGA recommend that the correct fitting tool (OEM Part No. T10134) is used when assembling OC6316 - OC6317 - OC6322 - OC6325 - OC6326 - OC6335.

The purpose of this tool is to sit the oil seal flange evenly, failure to do this can cause the engine not to start, poor running of the engine, and/or additional stress to the housing which may damage the seal.

### STEP 1

- Attach new BGA Oil seal to alignment tool T10134.

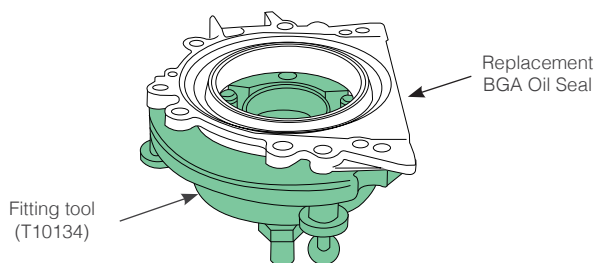

### STEP 2

- Ensure timing mark is aligned with the peg on the fitting tool.

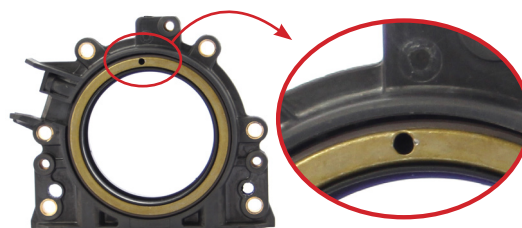

### STEP 3

- Attach oil seal and fitment tool to the crankshaft, and insert the relevant locating pin.

- Black locking Pin for Diesel
- Red locking Pin for Petrol

### STEP 4

- Tighten the bolts to secure the unit to the engine. Tightening torque: **35 Nm**.



### STEP 5

- Remove the fitting tool (T10134) and check the installation. The sender wheel is positioned correctly on the crankshaft if the distance between the crankshaft flange (A) and sender wheel (B) is **0.5 mm**.

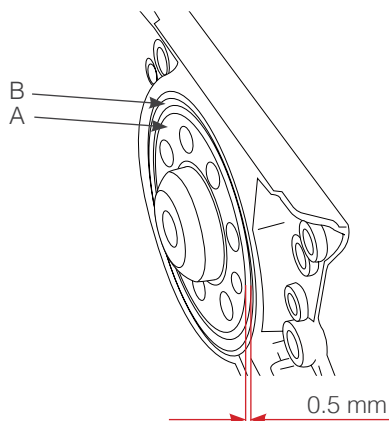

### IMPORTANT

- If the distance between the crankshaft flange and sender wheel is not **0.5mm**, re-apply alignment tool and tighten in 2.5 Nm increments until the distance is correct. If the distance is not 0.5mm, the engine will run poorly, or fail to start.
- Do not start the engine for at least 4 hours after installation, as new seal lip needs time to settle before the engine can be started.



BGA products are to be replaced by an experienced automotive installer. This information is to be used as reference only. Always seek manufacturer specification.