

QUICK BRAKE®



Quick Brake - The Brake Accessory specialist from Denmark

The manufacturer OJD QUICK BRAKE has more than 49 years of experience in brake accessories. With our extensive product range OJD QUICK BRAKE covers more than 90% of the European and Asian vehicle types.

Through constant development our product lines are updated accordingly to requests in the market.

Our Product Range includes:

- Brake Line Tubes
- Various Loose Parts (Screws, Fittings, Bolts etc.)
- Brake Accessory Kits
- Brake Wear Sensors
- Brake Hoses

OJD QUICK BRAKE is certified according to the quality standard system ISO 9001 and ISO 14001. Furthermore, we are approved supplier to main brake system and brake pad/shoe manufacturers.



Workshop Kit

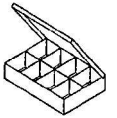

Fittings for Brake Line Tubes

Ref. 0001



Ref.	d1	d2	s x tl	Pcs.
A	M10 x 1	ø5,0	11 x 16,7	20
B	M12 x 1	ø6,0	12 x 18,0	5
B5.0	M12 x 1	ø5,0	12 x 20,0	5
E	M10 x 1	ø5,0	14 x 14,0	5
F	3/8" x 24 UNF	ø5,0	11 x 21,0	20
H	3/8" x 24 UNF	ø5,0	14 x 17,5	5
J	3/8" x 24 UNF	ø5,0	10 x 14,4	5
KX	3/8" x 24 UNF	ø5,0	12 x 16,0	5
L	M10 x 1,25	ø5,0	10 x 19,5	10
M	M10 x 1,25	ø5,0	10 x 14,2	10
S	3/8" x 24 UNF	ø5,0	10 x 18,0	10
TX	M10 x 1	ø5,0	10 x 18,0	10
Total				110

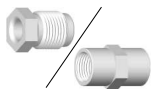

Fittings and Connectors for Brake Line Tubes

Ref. 0001A



Ref.	d1	d2	s x tl	Pcs.
BX	M12 x 1	ø6,5	12 x 18,0	5
C	M10 x 1	ø5,0	11 x 24,8	5
EV	M10 x 1	ø5,0	14 x 15,0	5
OAA	M10 x 1	ø3,5	14 x 24,0	5
OBB	M12 x 1	ø4,0	17 x 29,0	2
OFF	3/8" x 24 UNF	ø6,1	14 x 33,2	2
OKK	3/8" x 24 UNF	ø3,2	11 x 28,0	2
PA	7/16" x 24 UNS	ø6,5	12 x 15,5	2
PF	1/2" x 20 UNF	ø5,0	13 x 18,0	2
PG	7/16" x 20 UNF	ø5,0	12 x 21,5	5
T	M10 x 1	ø5,0	10 x 18,0	5
X	For one 3/16" or 5 mm tube			5
Total				45

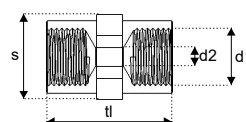
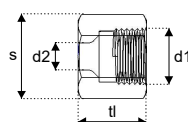
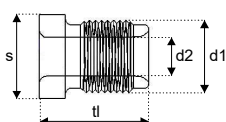

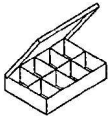

Workshop Kit



Fittings for Brake Line Tubes

Ref. 0001B



Ref.	d1	d2	s x tl	Pcs.
A	M10 x 1	ø5,0	11 x 16,7	10
B	M12 x 1	ø6,0	12 x 18,0	5
B5.0	M12 x 1	ø5,0	12 x 20,0	5
BX	M12 x 1	ø6,5	12 x 18,0	4
C	M10 x 1	ø5,0	11 x 24,8	4
D	M10 x 1	ø5,0	10 x 16,7	5
E	M10 x 1	ø5,0	14 x 14,0	5
EV	M10 x 1	ø5,0	14 x 15,0	4
F	3/8" x 24 UNF	ø5,0	11 x 21,0	5
H	3/8" x 24 UNF	ø5,0	14 x 17,5	4
J	3/8" x 24 UNF	ø5,0	10 x 14,4	4
KX	3/8" x 24 UNF	ø5,0	12 x 16,0	4
L	M10 x 1,25	ø5,0	10 x 19,5	5
M	M10 x 1,25	ø5,0	10 x 14,2	4
PF	1/2" x 20 UNF	ø5,0	13 x 18,0	4
S	3/8" x 24 UNF	ø5,0	10 x 18,0	5
T	M10 x 1	ø5,0	10 x 18,0	4
TX	M10 x 1	ø5,0	10 x 18,0	10
Total				91



Connectors for Brake Line Tubes

Ref. 0001C



Ref.	d1	d2	s x tl	Pcs.
OAA	M10 x 1	ø3,5	14 x 24,0	2
OBB	M12 x 1	ø4,0	17 x 29,0	2
ODD	M10 x 1	ø3,5	14 x 24,0	2
OEE	M10 x 1	ø3,2	11 x 28,0	2
OFF	3/8" x 24 UNF	ø3,1	14 x 33,2	2
OKK	3/8" x 24 UNF	ø3,2	11 x 28,0	2
O3A	M10 x 1	-	-	1
O3B	M12 x 1	-	-	1
OAE	M10 x 1	ø3,5	14 x 29,0	2
OBE	M12 x 1	ø3,2	15 x 32,0	2
STT	Connector for 3/16" tubes			2
STT5.0	Connector for 5 mm tubes			2
Total				25

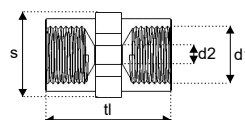
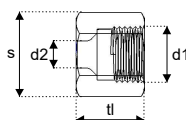
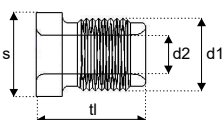

Workshop Kit

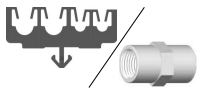
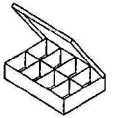

Clips & Connectors for Brake Line Tubes

Ref. 0001D



Ref.		Pcs.
W	For two 3/16" or 5 mm tubes	4
WA	For two 3/16" or 5 mm tubes	4
WB	For three 3/16" or 5 mm tubes	4
WD	For two 3/16" or 5 mm tubes and two 5/16" or 8 mm tubes	2
X	For one 3/16" or 5 mm tube	4
XA	For one 3/16" or 5 mm tube	4
XB	For one 1/4" or 6 mm tube	4
XC	For one 5/16" or 8 mm tube	4
STT	Connector for 3/16" tubes	2
STT5.0	Connector for 5 mm tubes	2
STT6.0	Connector for 6 mm tubes	2
STT8.0	Connector for 8 mm tubes	2
Total		38



Bleeder Screws

Ref. 0002



Ref.	d	s x tl	Pcs.
0010	M8 x 1,25	9 x 41,5	5
0017	M10 x 1	10 x 34,0	5
0033	M6 x 1	7 x 29,0	5
0039	M10 x 1	11 x 29,9	5
0053	M7 x 1	7 x 21,7	5
0086	M7 x 1	7 x 30,5	5
0087	M7 x 1	7 x 38,3	5
0100	M8 x 1,25	8 x 24,5	5
0107	3/8" x 24 UNF	10 x 31,0	5
0108	3/8" x 24 UNF	10 36,7	5
0120X	1/4" x 24 UNF	8 x 28,0	5
0125	Dust cap		20
Total			75

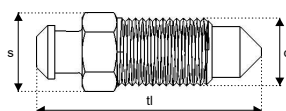

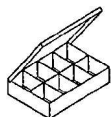

Workshop Kit



Bleeder Screws

Ref. 0002A



Ref.	d	s x tl	Pcs.
0011	M8 x 1,25	9 x 35,5	5
0013	M6 x 1	7 x 38,0	5
0015	M8 x 1,25	9 x 32,5	5
0018	M10 x 1	10 x 36,5	5
0019	M10 x 1	11 x 36,0	5
0069	M7 x 1	7 x 28,6	5
0085	M8 x 1,25	9 x 49,0	5
0088	M7 x 1	9 x 33,0	5
0089	M8 x 1	8 x 32,0	5
0090	M8 x 1	9 x 33,5	5
0094	M7 x 1	8 x 55,5	5
0125	Dust cap		20
Total			75



Fixing Screws for disc and drum brakes

Ref. 0004B



Ref.	d	s x tl	Pcs.
11660	M6 x 1	14,0 x 15,0	4
11661	M8 x 1	14,0 x 12,5	4
11662	M8 x 1,25	15,9 x 15,7	6
11663	M8 x 1,25	15,5 x 17,0	4
11664	M12 x 1,5	18,8 x 21,3	6
11665	M8 x 1,25	15,8 x 16,1	4
11666	M10 x 1,25	13,3 x 19,4	4
11667	M6 x 1	11,0 x 16,1	6
11668	M8 x 1,25	10,9 x 15,6	6
11669	M10 x 1,5	10,0 x 18,9	4
11670	M10 x 1,5	18,0 x 19,7	6
11671	M6 x 1	11,0 x 14,0	4
Total			58

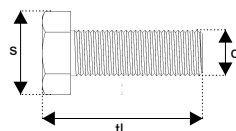
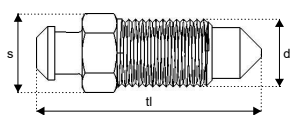

Workshop Kit



Fixing Screws for disc and drum brakes

Ref. 0004C

NEW



Ref.	d	s x tl	Pcs.
11558X	M10 x 1,50	13 x 38,6	5
11622	M6 x 1	11,7 x 19,9	5
11667	M6 x 1	11 x 16,1	5
11671	M6 x 1	11 x 14	5
11672	M8 x 1,25	11,8 x 17,8	5
11673	ø21,5 x 5,25	-	5
11674	M8 x 1,25	12 x 36,6	5
11675	M10 x 1,50	15,5 x 27,3	5
11676	M8 x 1,25	14,3 x 20	5
11677	M10 x 1,25	15,9 x 38	5
11678	M8 x 1,50	12 x 31,6	5
11679	M10 x 1	20,6 x 22	5
Total			60



Clips for Brake Hoses

Ref. 0009



Ref.	d	Pcs.	
3200	-	4	
3201	-	4	
3202	-	6	
3203	-	4	
3205	-	4	
3206	-	4	
3207	-	4	
3208	-	4	
3209	-	4	
3210	-	4	
3212	-	6	
3213	-	4	
3214	-	2	
3216	-	2	
3219	-	4	
3220	-	4	
3211	ø10 x 1,5	Copper	10
3218	ø12,3 x 0,8	Copper	4
Total		78	

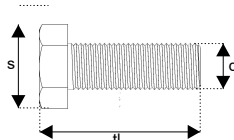

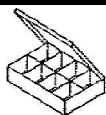

Workshop Kit



Banjo Bolts for Brake Hoses

Ref. 0009A



Ref.	d	s x tl	Pcs.
3250	M12 x 1	17 x 24,0	4
3251	M10 x 1	14 x 27,1	4
3252	M10 x 1,5	11 x 28,1	4
3253	M12 x 1	13 x 28,9	4
3254	M10 x 1	16 x 32,3	4
3255	M12 x 1	17 x 28,0	4
3256	M10 x 1	12 x 31,4	4
3257	M10 x 1,5	12 x 30,5	4
3258	M10 x 1	11 x 37,0	4
3259	M10 x 1	13 x 27,2	4
3211	ø10,0 x 1,5	Copper	6
3218	ø12,3 x 0,8	Copper	6
3225	ø10,0 x 1,5	Aluminium	6
3226	ø12,0 x 1,5	Aluminium	6
Total			64

Brake Lines

Copper, Copper-Nickel

Ref. D115
(Display complete)

Ref.	Length (mm)	pcs.
0150 A-A	150	2
0200 A-A	200	2
0260 A-A	260	2
0300 A-A	300	2
0360 A-A	360	2
0410 A-A	410	2
0450 A-A	450	2
0510 A-A	510	2
0550 A-A	550	2
0610 A-A	610	2
0650 A-A	650	2
0700 A-A	700	2
0750 A-A	750	2
0800 A-A	800	2
0860 A-A	860	2
0900 A-A	900	2
0960 A-A	960	2
1000 A-A	1000	2



Brake lines are with fittings and single flarings

Please Note: Quick Brake have loose Brake Tubes up to 5,5 meters

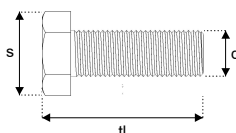

Brake Lines

Copper, Copper-Nickel and Steel



Copper

Ref.	Diameter	Length
1910 CU	3/16"	7,62 m
1910R CU-5M	3/16"	5 m
1911R CU-10M	3/16"	10 m
1911R CU-25M	3/16"	25 m
1911 CU RING	3/16"	50 m
1912 CU RING	3/16"	142 m
1920 CU	1/4"	7,62 m
1922 CU RING	1/4"	100 m
1930 CU	5/16"	7,62 m
1932 CU RING	5/16"	77 m
1940 CU	3/8"	7,62 m
1942 CU RING	3/8"	63 m
1950 CU	5 mm	5 m
1951 CU RING	5 mm	50 m
1952 CU RING	5 mm	134 m
1960 CU	6 mm	5 m
1962 CU RING	6 mm	107 m
1970 CU	8 mm	5 m
1972 CU RING	8 mm	75 m
1972 CU RING	8 mm	75 m
1980 CU	10 mm	5 m
1982 CU RING	10 mm	60 m



Copper-Nickel

Ref.	Diameter	Length
1915 CUNI	3/16"	5 m
1917 CUNI RING	3/16"	10 m
1916 CUNI RING	3/16"	25 m
1925 CUNI	1/4"	5 m
1935 CUNI	5/16"	5 m
1965 CUNI	6 mm	5 m
1967 CUNI RING	6 mm	10 m

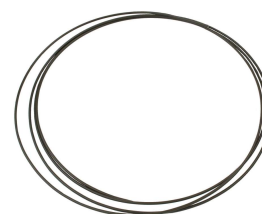

Steel

Ref.	Diameter	Length
0181 ST RING	3/16"	5 m
0186 ST RING	6 mm	5 m

All Brake Tubes from Quick Brake are available in **TecDoc**.

The Quick Repair System for drum brakes

Accessory Kits for brake shoes
(105-XXXX)



Self Adjuster Kits
(102 53 XXX)



Expander Lock Kits for hand brake shoes
(120 53 XXX)

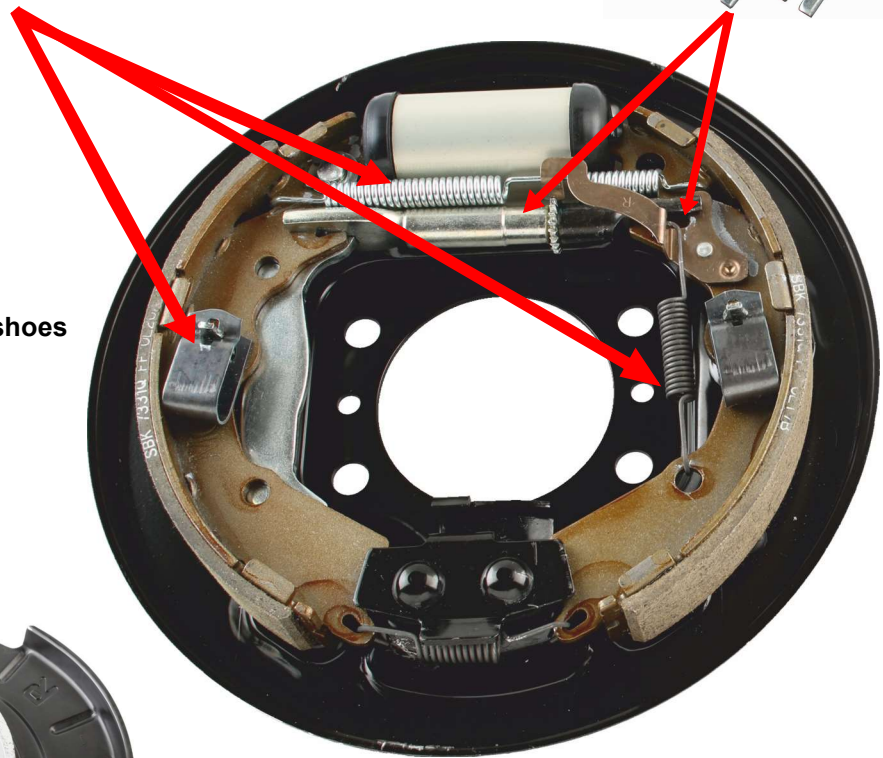

When changing the brake shoes, for technical and safety reasons, it is also recommended to change the Accessory Kit and the Brake Adjuster Kit for brake shoes.

The Quick Repair System for disc brakes

Brake caliper Piston Seal Kit
(114-XXXX) - Wheel kit



Guide Sleeve Kit
(113-XXXX) - Wheel kit



Accessory Kit for brake pads
(109-XXXX) - Axle kit



Brake Wear Sensor
(WS XXXX A)

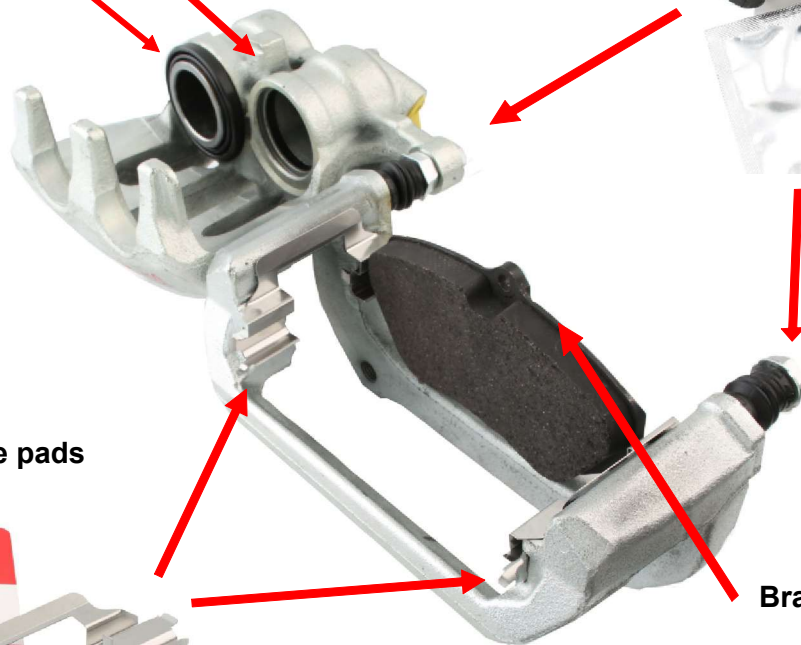





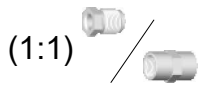





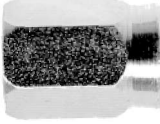

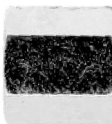
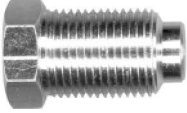
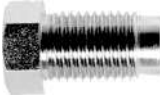
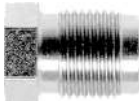

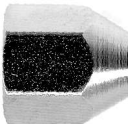
When repairing the caliper, for technical and safety reasons, it is also recommended to change the Guide Sleeve Kit and Accessory Kit to ensure perfect function.

QUICK BRAKE®







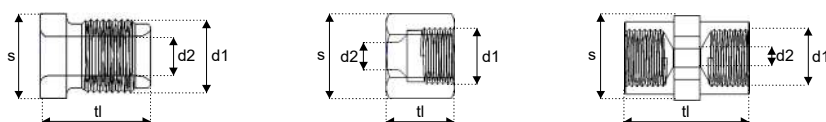



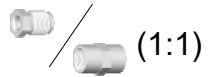



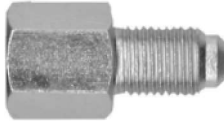

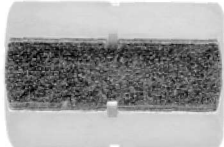

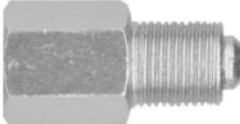
Brake Line Fittings, Clips & Connectors

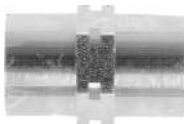
	d1	d2	s x tl		d1	d2	s x tl
A  Available in stainless steel (Ref: A-A2)	M10 x 1	ø5,0	11 x 16,7	E 	M10 x 1	ø5,0	14 x 14,0
	Alfa Romeo, Audi, BMW, Chevrolet, Citroën, Dacia, Fiat, Ford, Honda, Hyundai, Kia, Mitsubishi, Mercedes, Nissan, Opel, Peugeot, Renault, Rover, Saab, Seat, Skoda, Suzuki, Toyota, Volvo, VW				Alfa Romeo, Audi, Citroën, Fiat, Ford, Opel, Peugeot, Renault, Rover, Seat, Saab, Volvo, VW		
B 	M12 x 1	ø6,0	12 x 18,0	EB 	M12 x 1	ø5,0	15 x 21,5
	Audi, Ford, Peugeot, Saab, Seat, Volvo, VW				Citroën, Ford, Peugeot, Seat, VW		
B5.0 	M12 x 1	ø5,0	12 x 20,0	EV 	M10 x 1	ø5,0	14 x 15,0
	Alfa Romeo, Audi, BMW, Citroën, Chevrolet, Daewoo, Fiat, Ford, Honda, Mazda, Nissan, Opel, Peugeot, Renault, Seat, Skoda, Saab, Suzuki, Volvo, VW				Opel, Volvo		
B5L 	M12 x 1	ø5,0	13 x 24,0	F 	3/8" x 24UNF ø5,0		11 x 21,0
	Alfa Romeo, Citroën, Fiat, Mazda, Peugeot				Renault, Saab, Vauxhall, Volvo		
BX 	M12 x 1	ø6,5	12 x 18,0	G 	3/8" x 20UNF ø5,0		11 x 22,4
					Rover		
C 	M10 x 1	ø5,0	11 x 24,8	H 	3/8" x 24UNF ø5,0		14 x 17,5
	Hyundai				Bedford, Rover, Saab, Talbot, Vauxhall, Volvo		
CI 0216X 	M8 x 1,25	ø3,8	8 x 19,5	HA 	M10 x 1	ø5,0	15 x 23,0
	Citroën				Alfa Romeo, Citroën, Fiat, Mazda, Mercedes, Nissan, Opel, Seat		
CI 0217 	M9 x 1,25	ø4,8	9 x 20,8	J 	3/8" x 24UNF ø5,0		10 x 14,4
	Citroën				Volvo and US cars		
D 	M10 x 1	ø5,0	10 x 16,7	KX 	3/8" x 24UNF ø5,0		12 x 16,0
	Chevrolet, Daihatsu, Daewoo, Hyundai, Kia, Nissan, Opel, Skoda, Toyota, Vauxhall, VW				Volvo		
DL 	M10 x 1	ø5,0	10 x 23,0	L 	M10 x 1,25	ø5,0	10 x 19,5
	Honda, Kia, Suzuki, Toyota, Volvo, VW				Autobianchi, Dacia, Fiat, Lada, Lancia, Zastava		

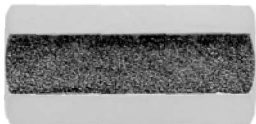
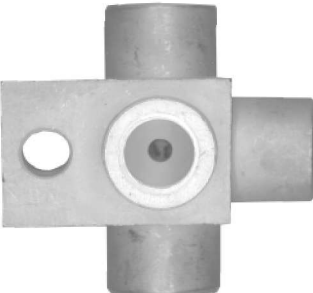

Brake Line Fittings, Clips & Connectors

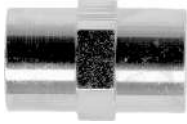



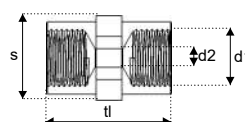
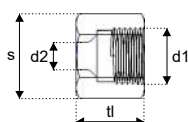
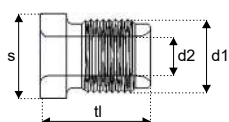





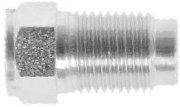

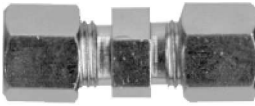

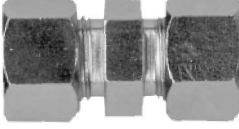

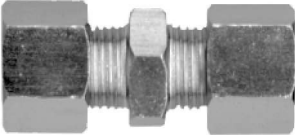

		d1	d2	s x tl			d1	d2	s x tl
M		M12 x 1,25	ø5,0	10 x 14,2	OAE		2 x M10 x 1	ø3,5	14 x 29,0
		Mazda					Connector		For single/double flaring.
N		M12 x 1,25	ø6,5	14 x 19,4	OBB		2 x M12 x 1	ø4,0	17 x 29,0
		Eastern European + Fiat 238					For double flaring.		
N5.0		M12 x 1,25	ø5,0	13 x 19,5	OBE		2 x M12 x 1	ø3,2	15 x 32,0
		Iveco					Connector		For single/double flaring.
O3A		3 x M10 x 1			ODD		2 x M10 x 1	ø3,5	14 x 24,0
		For single flaring.					For double flaring.		
O3B		3 x M12 x 1			OEE		2 x M10 x 1	ø3,2	11 x 28
		For double flaring.					For double flaring.		
O3D		3 x M10 x 1			OFF		2 x 3/8" x 24UNF	ø3,1	14 x 33,2
		For double flaring.					For single flaring.		
O4A		4 x M10 x 1			OKK		2 x 3/8" x 24UNF	ø3,2	11 x 28,0
		For single flaring.					For double flaring		
OAA		2 x M10 x 1	ø3,5	14 x 24,0	P		7/16" x 24UNS	ø5,0	12 x 23,0
		For single flaring.					Peugeot		

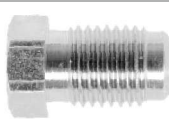
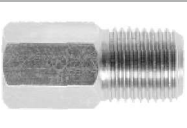
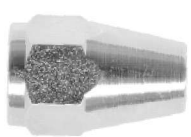



Brake Line Fittings, Clips & Connectors



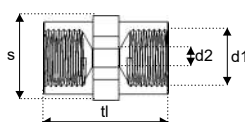
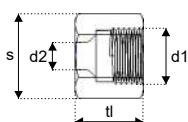
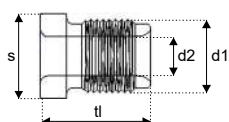





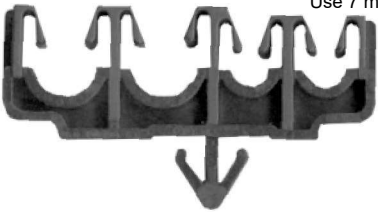
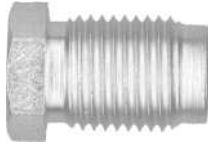

		d1	d2	s x tl		d1	d2	s x tl
P6.5		7/16" x 24UNS	ø6,5	12 x 22,7	STT			Connector for 3/16" tubes Assembles without flarings For Cu, CuNi and Steel Brake Lines
PA		7/16" x 24UNS	ø6,5	12 x 15,5	STT5.0			Connector for 5 mm tubes Assembles without flarings For Cu, CuNi and Steel Brake Lines
PA5.0		7/16" x 24UNS	ø5,0	11 x 21,0	STT6.0			Connector for 6 mm tubes Assembles without flarings For Cu, CuNi and Steel Brake Lines
PE		1/2" x 20UNF	ø8,0	13 x 15,8	STT8.0			Connector for 8 mm tubes Assembles without flarings For Cu, CuNi and Steel Brake Lines
PF		1/2" x 20UNF	ø5,0	13 x 18,0	T		M10 x 1	ø5,0 10 x 18,0
PF6.0		1/2" x 20UNF	ø6,2	13 x 17,0	TX		M10 x 1	ø5,0 10 x 18,0 Chevrolet, Daewoo, Daihatsu, Honda, Hyundai, Isuzu, Mazda, Mitsubishi, Nissan, Opel, Suzuki, Toyota, VW
PG		7/16" x 20UNF	ø5,0	12 x 21,5	TXL		M10 x 1	ø5,0 10 x 21,0 Kia, Nissan, Suzuki, Toyota
PH		7/16" x 20UNF	ø6,5	14 x 24,0	W			For fastening two 3/16" or 5 mm tubes
PX		7/16" x 20UNF	ø6,5	12 x 23,0	WA			For fastening two 3/16" or 5 mm tubes Use 8 mm drill
S		3/8" x 24UNF	ø5,0	10 x 18,0	WB			For fastening three 3/16" or 5 mm tubes Use 7 mm drill

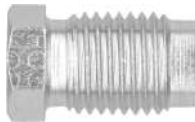

Brake Line Fittings, Clips & Connectors

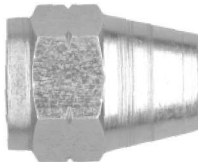
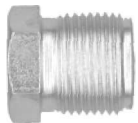

(1:1)

	d1	d2	s x tl		d1	d2	s x tl	
WD				<p>For fastening two 3/16" or 5 mm, and two 5/16" or 8 mm tubes</p> <p>Use 7 mm drill</p> 	ZC			<p>M16 x 1,5 ø10,6 17 x 26,5</p> <p>Audi, BMW, MAN, Mercedes, VW</p> 
X				<p>For fastening one 3/16" or 5 mm tube</p> <p>Use 6 mm drill</p> 	ZD			<p>5/8" x 18UNF ø10,2 17 x 16,5</p> 
XA				<p>For fastening one 3/16" or 5 mm tube</p> <p>Use 7 mm drill</p> 	ZE			<p>M14 x 1,5 ø8,5 14 x 25,0</p> <p>Audi, BMW, MAN, Mercedes, VW</p> <p>For double flaring.</p> 
XB				<p>For fastening one 1/4" or 6 mm tube</p> <p>Use 7 mm drill</p> 	ZF			<p>M14 x 1,5 ø8,4 19 x 29,0</p> 
XC				<p>For fastening one 5/16" or 8 mm tube</p> <p>Use 7 mm drill</p> 	ZG			<p>M16 x 1,5 ø10,3 19 x 25,5</p> 
Z				<p>M14 x 1 ø8,2 14 x 16,5</p> <p>Audi, BMW, MAN, Mercedes, VW</p> <p>For single flaring</p> 				
ZA				<p>M14 x 1 ø8,2 14 x 16,5</p> <p>Audi, BMW, MAN, Mercedes, VW</p> <p>For double flaring.</p> 				
ZB				<p>M14 x 1,5 ø8,2 14 x 25,5</p> <p>Audi, BMW, MAN, Mercedes, VW</p> <p>For single flaring.</p> 				

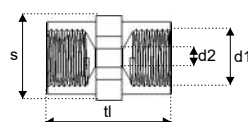
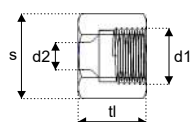
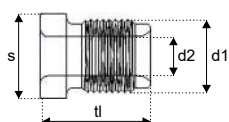

(1:1)



Bleeder Screws



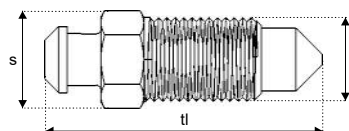







	d1	s x tl		d1	s x tl
0010	M8 x 1,25	9 x 41,5	Citroën, Fiat, Lancia, Mercedes, Opel, Peugeot, Seat, Skoda, Smart, Vauxhall, Volvo, VW	0033	M6 x 1 7 x 29,0 Audi, BMW, Fiat, Mercedes, Opel, Saab, Seat, VW
0011	M8 x 1,25	9 x 35,5	Chevrolet, Chrysler, Citroën, Daewoo, Ford, Honda, Mercedes, Mini, Opel, Renault, Saab, Skoda, Suzuki, Vauxhall, Volvo	0039	M10 x 1 11 x 29,9 Alfa Romeo, Audi, Austin, BMW, Chevrolet, Chrysler, Citroën, Daewoo, Daihatsu, Dodge, Fiat, Ford, Honda, Hyundai, Iveco, Jaguar, Kia, Land Rover, Mazda, Mercedes, Mitsubishi, Nissan, Opel, Peugeot, Renault, Rover, Saab, Seat, Skoda, Ssangyong, Subaru, Suzuki, Toyota, Vauxhall, Volvo, VW Available in stainless steel (Ref: 0039-A2)
0013	M6 x 1	7 x 38,0	Audi, Seat, Skoda, Subaru, VW	0040	M12 x 1 13 x 31,4 Ford
0015	M8 x 1,25	9 x 32,5	Alfa Romeo, Audi, BMW, Chevrolet, Citroën, Fiat, Ford, Honda, Land Rover, Mazda, Mercedes, Mini, Nissan, Opel, Peugeot, Renault, Saab, Seat, Skoda, Toyota, Vauxhall, Volvo, VW	0053	M7 x 1 7 x 21,7 Alfa Romeo, BMW, Citroën, Dacia, Daihatsu, Fiat, Ford, Hyundai, Isuzu, Mazda, Mitsubishi, Nissan, Opel, Peugeot, Renault, Rover, Seat, Skoda, Smart, Talbot, Vauxhall, Volvo, VW
0016	M10 x 1	10 x 31,6	Chevrolet, Hyundai, Kia	0053X	M7 x 1 7 x 26,2 Citroën, Fiat, Ford, Mercedes, Nissan, Opel, Peugeot, Renault, Smart, Suzuki, Volvo
0017	M10 x 1	10 x 34,0	Alfa Romeo, Audi, BMW, Chevrolet, Daewoo, Daihatsu, Ford, Honda, Hyundai, Isuzu, Kia, Lancia, Mazda, Mini, Mitsubishi, Nissan, Opel, Peugeot, Renault, Rover, Skoda, Subaru, Suzuki, Toyota, Vanden Plas, Vauxhall, Volvo, VW	0069	M7 x 1 7 x 28,6 Alfa Romeo, Citroën, Fiat, Ford, Isuzu, Lancia, Mazda, Mitsubishi, Nissan, Peugeot, Renault, Rover, Seat, Skoda, Suzuki, Talbot, Toyota, Volvo
0018	M10 x 1	10 x 36,5	Daihatsu, Ford, Iveco, Rover, Talbot (Simca), Toyota, Triumph	0085	M8 x 1,25 9 x 49,0 Ford, Mercedes
0019	M10 x 1	11 x 36,0	Alfa Romeo, Audi, BMW, Chevrolet, Citroën, Daewoo, Fiat, Ford, Honda, Hyundai, Kia, Lancia, Land Rover, Mazda, Mercedes, MG, Mitsubishi, Nissan, Opel, Peugeot, Seat, Skoda, Ssangyong, Subaru, Suzuki, Toyota, Volvo, VW	0086	M7 x 1 7 x 30,5 Alfa Romeo, Audi, BMW, Citroën, Daihatsu, DAF, Fiat, Ford, Honda, Jaguar, Lancia, Land Rover, Mazda, Mercedes, Mitsubishi, Nissan, Opel, Peugeot, Renault, Rover, Saab, Seat, Subaru, Suzuki, Talbot, Toyota, Volvo, VW
0020	M10 x 1	11 x 41,8	Mercedes With rubber seal	0087	M7 x 1 7 x 38,3 Alfa Romeo, Audi, BMW, Citroën, Daihatsu, Ford, Mazda, Opel, Peugeot, Renault, Saab, Seat, Skoda, Subaru, Talbot, Toyota, Vauxhall, Volvo, VW

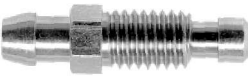

Bleeder Screws

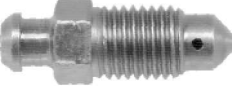

(1:1)

	d1	s x tl		d1	s x tl
0088	M7 x 1	9 x 33,0		0103	M10 x 1,5 10 x 29,5
	Citroën, Daihatsu, Fiat, Mazda, Mercedes, Mitsubishi, Nissan, Opel, Peugeot, Renault, Saab, Subaru, Suzuki, Toyota, Vauxhall				Cadillac, Chevrolet, Chrysler, Ford, Opel, Pontiac
0089	M8 x 1	8 x 32,0		0105	1/4" x 28UNF 7 x 28,5
	Ford, Kia, Mazda				Rover, Vauxhall
0090	M8 x 1	9 x 33,5		0107	3/8" x 24UNF 10 x 31,0
	Kia, Mazda, Mercedes, Mitsubishi, Opel, Saab, Suzuki, Toyota, Vauxhall				Chrysler, Ford, Hyundai, MG, Mitsubishi, Nissan, Rover, Sunbeam, Suzuki, Talbot, Vauxhall, Volvo
0091	M8 x 1	8 x 38,0		0108	3/8" x 24UNF 10 x 36,7
	Mazda				Jaguar, Lotus, Morgan, Rover, Saab, Sunbeam, Talbot, Triumph, Vauxhall
0092	M8 x 1,25	8 x 34,7		0120X	1/4" x 28UNF 8 x 28,0
					Iveco, Rover, Volvo
0093	M8 x 1,0	8 x 28,0		0122	5/16" x 24UNF 8 x 25,5
	Hyundai, Kia, Mazda, Mitsubishi, Suzuki				Hyundai, Kia
0094	M7 x 1	8 x 55,5		0123	M10 x 1,5 10 x 37,6
	Ford, Mitsubishi				Chrysler
0100	M8 x 1,25	8 x 24,5		0125	Dust Cap All Bleeder Screws
	Alfa Romeo, Autobianchi, Citroën, Daewoo, Fiat, Ford, Honda, Jaguar, Kia, Lada, Lancia, Mazda, Mercedes, Mitsubishi, Nissan, Opel, Peugeot, Polmo, Renault, Rover, Saab, Seat, Talbot, Toyota, Vanden-Plas, Vauxhall, Wartburg, Zastava				
0101	M10 x 1,25	10 x 28,0		0126	Dust Cap All Bleeder Screws
	Honda, Rover				
0102	M10 x 1,25	10 x 33,0			
	Honda, Rover				

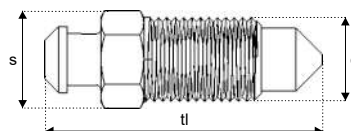

(1:1)



Brake Hose Clips & Washers

3200

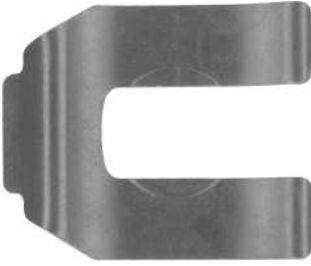

Fiat, Mercedes, Opel, Renault, Skoda, Vauxhall, VW

3208

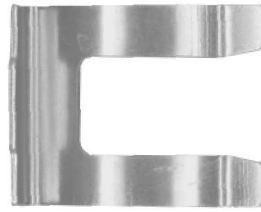

Alfa Romeo, Daihatsu, Ford, Hyundai, Kia, Mazda, Mitsubishi, Nissan, Suzuki, Volvo

3201



Alfa Romeo, Autobianchi, Citroën, Fiat, Ford, Kia, Lada, Lancia, Land Rover, Opel

3209

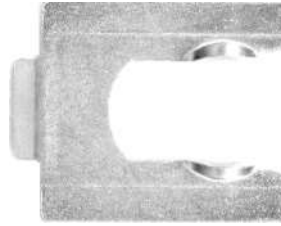

Citroën, Fiat, Lancia, Peugeot, Renault, Peugeot, Saab, Seat, Smart, Vauxhall, VW, Zastava

3202



Alfa Romeo, Audi, BMW, Citroën, Dacia, Mercedes, Mini, Nissan, Opel, Peugeot, Renault, Seat, Talbot, Toyota, Vauxhall, VW

3210



Daihatsu, Lexus, Toyota, VW

3203

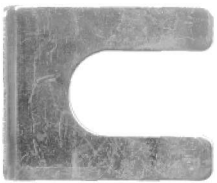

Daihatsu, Mercedes, Subaru, Toyota

3211



ø10 x 1,5
Copper
UNIVERSAL

3205

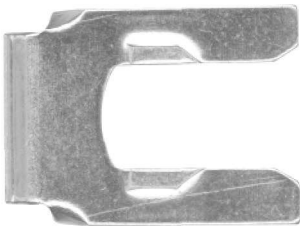

Alfa Romeo, Citroën, Fiat, Kia, Lancia, Mazda, Mercedes, Peugeot, Talbot

3212



Alfa Romeo, Audi, Citroën, Dacia, Land Rover, Mercedes, Mitsubishi, Nissan, Opel, Peugeot, Porsche, Renault, Rover, Seat, Skoda, Saab, Toyota, Vauxhall, Volvo, VW

3206

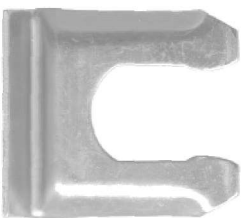

Bedford, Chevrolet, Daewoo, Ford, Isuzu, Opel, Rover, Saab, Suzuki, Vauxhall

3213



Ford, Jaguar, Kia, Mazda

3207



Audi, BMW, Fiat, Honda, Lancia, Land Rover, Mazda, MG, Rover, Seat, Skoda, VW

3214





Ford

Brake Hose Clips & Washers

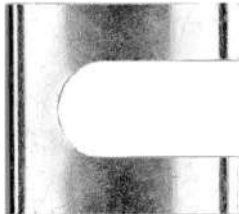



3216  Citroën, Daihatsu, Honda, Lexus, Peugeot, Toyota

3223  Mercedes

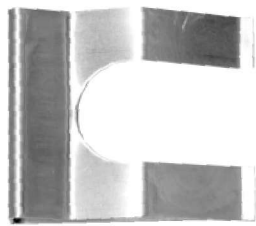
3217  Hyundai, Kia, Mitsubishi, Opel, Smart, Subaru, Suzuki, Vauxhall

3224  Renault

3218  $\varnothing 12,3 \times 0,8$
Copper
UNIVERSAL

3225  $\varnothing 10,0 \times 1,5$
Aluminium
UNIVERSAL

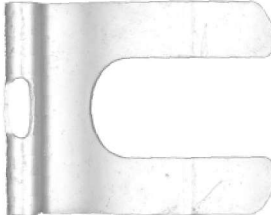
3219  Ford, Hyundai, Kia, Mazda

3226  $\varnothing 12,0 \times 1,5$
Aluminium
UNIVERSAL

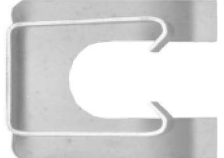
3220  Subaru

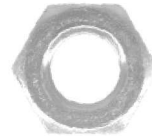
3231  M10 x 1 17 x 8
Volvo 240

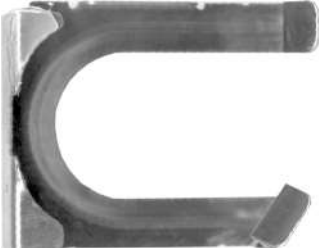
3221  BMW

3232  $3/8" \times 24\text{UNF}$ 14 x 5,5

3222  BMW

(1:1)







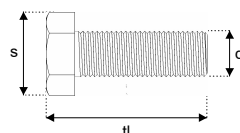

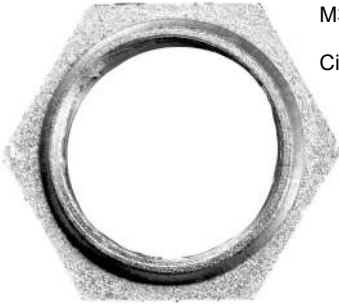

Brake Hose Banjo Bolts

	d	s x tl		d	s x tl	
3250	M12 x 1	17 x 24,0		3258	M10 x 1 Opel	11 x 37,0
3251	M10 x 1 Honda, Mitsubishi, Toyota	14 x 27,1		3259	M10 x 1 Mitsubishi	13 x 27,2
3252	M10 x 1,5 Opel	11 x 28,1		3260	M10 x 1,5 VAG	11 x 28,1
3253	M12 x 1 Saab	13 x 28,9		3261	M10 x 1 Fiat, Honda, Mazda, Opel, Suzuki, Toyota	14 x 32,2
3254	M10 x 1 Ford	16 x 32,3		3262	M10 x 1 Kia, Mitsubishi	12 x 29,2
3255	M12 x 1	17 x 28,0		3263	M10 x 1 Peugeot	13 x 25,6
3256	M10 x 1 Hyundai, Kia, Nissan	12 x 31,4				
3257	M10 x 1,5 Chevrolet, Opel	12 x 30,5				



Nuts, stub axle



	d	s x tl		d	s x tl
9802	M30 x 1,5	40,0 x 16,5	Citroën, Peugeot	9810	M20 x 1,5 34,1 x 17,9 Audi, Seat, Skoda, VW
					
9803	M28 x 1,5	36,0 x 19,0	Citroën, Fiat	9811	M20 x 1,5 30,0 x 20,0 Renault
					
9804	M22 x 1,5	32,0 x 16,6	Citroën, Fiat	9812	M24 x 2,0 36,0 x 23,7 Ford
					
9805	M18 x 1,5	26,0 x 16,5	Citroën, Peugeot	9813	M20 x 1,5 30,0 x 17,4 Ford, Mazda
					
9806	M20 x 1,5	30,0 x 14,7	VW		
					

(1:1)



Grease Caps, stub axle

TOP

SIDE

9821

Fits hole $\varnothing 59,0$  $\varnothing 62,0 \times 27,0$

9822

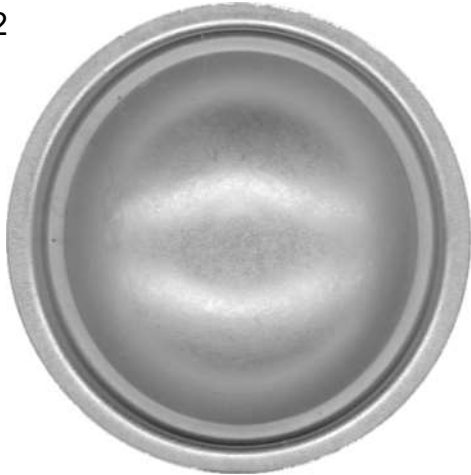
Fits hole $\varnothing 56,0$  $\varnothing 62,4 \times 12,0$

9823

Fits hole $\varnothing 56,0$  $\varnothing 56,4 \times 26,5$

9824

Fits hole $\varnothing 40,0$  $\varnothing 53,1 \times 15,2$

Grease Caps, stub axle



(1:1)

TOP

SIDE

9825

ø72,8 x 28,0



Fits hole ø70,0

9826

ø64,1 x 11,2



Fits hole ø60,0

9827

ø66,0 x 22,0



Fits hole ø58,0

(1:1)



Grease Caps, stub axle

TOP

SIDE

9828

ø59,2 x 16,4



Fits hole ø53,0

9829

ø54,5 x 21,5



Fits hole ø54,0

9841

ø21,0 x 0,8



Fixing Screws for disc and drum brakes



(1:1)

	d1	s x tl		d1	s x tl
11610	M16 x 1,5	21 x 61,6		M12 x 1,5	19 x 53,0
				With lock fluid	
11611	M12 x 1,5	20 x 81,8		M12 x 1,5	18 x 41,4
12EQS				With lock fluid	
11612	M12 x 1,5	20 x 76,8		M6 x 1	11,7 x 19,9
12EQS				Hexagon 4	
11613	M12 x 1,5	23,4 x 32,0		M6 x 1	12,0 x 13,0
Torx 70					
				With lock fluid	
11615	M10 x 1,5	17 x 28,4		M8 x 1,25	13 x 37,8
				Torx 40	
				With lock fluid	
11616	M12 x 1,5	19 x 37,0		2 BA	9,3 x 21,0
11617	M6 x 1	9,8 x 15,8		M12 x 1,5	19 x 42,5
Hexagon 5					
11618	M6 x 1	10,8 x 14,0		M8 x 1,25	13 x 23,2
PH slot					

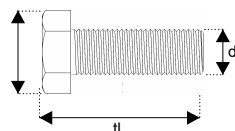



Fixing Screws for disc and drum brakes

	d1	s x tl		d1	s x tl
11630 12EQS	M14 x 1,5	29,6 x 53,6		11666 Hexagon 5	M10 x 1,25 13,3 x 19,4
11631 Hexagon 8	M10 x 1,25	18,8 x 30,0		11667 Torx 30	M6 x 1 11,0 x 16,1
11660 Hexagon 5	M6 x 1	14,0 x 15,0	With lock fluid	11668 Hexagon 5	M8 x 1,25 10,9 x 15,6
11661 Torx 30	M8 x 1	14,0 x 12,5	With lock fluid	11669 Torx 50	M10 x 1,5 10,0 x 18,9
11662 Hexagon 6	M8 x 1,25	15,9 x 15,7		11670 Torx 50	M10 x 1,5 18,0 x 19,7
11663 Torx 40	M8 x 1,25	15,5 x 17,0		11671 Torx 30	M6 x 1 11,0 x 14,0
11664 Torx 50	M12 x 1,5	18,8 x 21,3		11672 Torx 30	M8 x 1,25 11,8 x 17,8
11665 Hexagon 5	M8 x 1,25	15,8 x 16,1		11673 ø21,5 x 5,25	

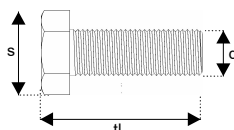

Fixing Screws for disc and drum brakes

(1:1)



	d1	s x tl		d1	s x tl
11674	M8 x 1,25	12,0 x 36,6		11678	M8 x 1,25 12,00 x 31,6
11675	M10 x 1,50	15,5 x 27,3	Hexagon 6 	11679	M10 x 1 20,6 x 22,0
11676	M8 x 1,25	14,3 x 20,0	PH 3 	11558X	M10 x 1,5 13 x 38,6
11677	M10 x 1,25	15,9 x 38,0		4904	M6 12,0

(1:1)



Glide Piece - backplate

6858K			Audi, Seat, Skoda, VW	
6859K			Skoda, VW	

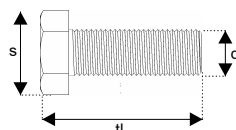



OJD Quick Brake ApS
Lerbaekvej 16
DK - 2680 Solroed Strand
Tlf: (+45) 56 14 14 28
Fax: (+45) 56 14 68 06
E-mail: ojd@ojd.dk
www.ojd.dk

QUICK BRAKE[®]